

COLLECTIONS
26/27



WHERE
QUALITY
MEETS
DESIGN

COLLECTIONS

INDEX

ABOUT CAESAR USA
2

SUSTAINABLE MIND
7

INSPIRE AND BE INSPIRED
8

**THE EXCELLENCE
OF CAESAR USA**
10

INSPIRE AND BE INSPIRED
12

JAPANESE STEPS
164

DECORS
172

BOND
14

COSMIX
22

CRETE
32

FOUNDRY26
42

GEMSTONE
50

LINK
58

NATURE
66

ORIGIN
74

PATHWAY
82

PLACE
90

REVIVE
98

RUN
106

SELECT
114

STONEWAYS
124

STYLE
132

WAVES
140

WHISPER
148

AEXTRA20
156

ABOUT CAESAR USA

MADE IN THE USA.

Caesar USA collections are manufactured in a cutting-edge facility in Tennessee. Our plant is centrally located to ensure faster and more convenient logistic services for the North American continent.

ADVANCED TECHNOLOGY

Decades of experience paired with the most modern technology puts Caesar Ceramics USA on the leading-edge of porcelain stoneware design. Producing products that are both beautiful and technical is Caesar's highest priority.

MADE FOR USA, WITH PASSION

Caesar USA products are developed to meet the technical and performance needs for any project, including full compliance to local standards and requirements. Homes and businesses can expect not only a beautiful and modern range of styles, but also peace of mind for choosing a long-lasting, high quality material."

◆ CAESAR ◆
CERAMICS USA

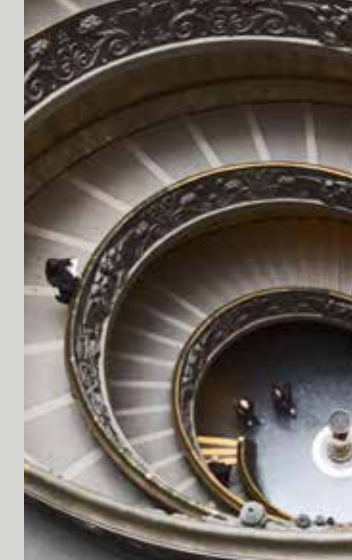



1988
CALIFORNIA
First export to the USA by
Ceramiche Caesar

1997
NEW JERSEY
Establishment of Caesar USA inc.
and logistic hub

2011
CALIFORNIA
Santa Fe Springs
Logistic hub

2016
INTRODUCING
MADE IN USA PRODUCTS
Caesar USA starts producing and
selling made in USA products

2018
TENNESSEE
Brentwood
New showroom and sales offices

CAESAR CERAMICS USA

Caesar USA boasts over 20 years of activity in the United States, as well as warehouses and sales offices, and has acquired great experience and knowledge of the needs and dynamics of the market. High quality products are made in in the USA utilizing state-of-the-art technology and years of expertise.

ABOUT CAESAR USA

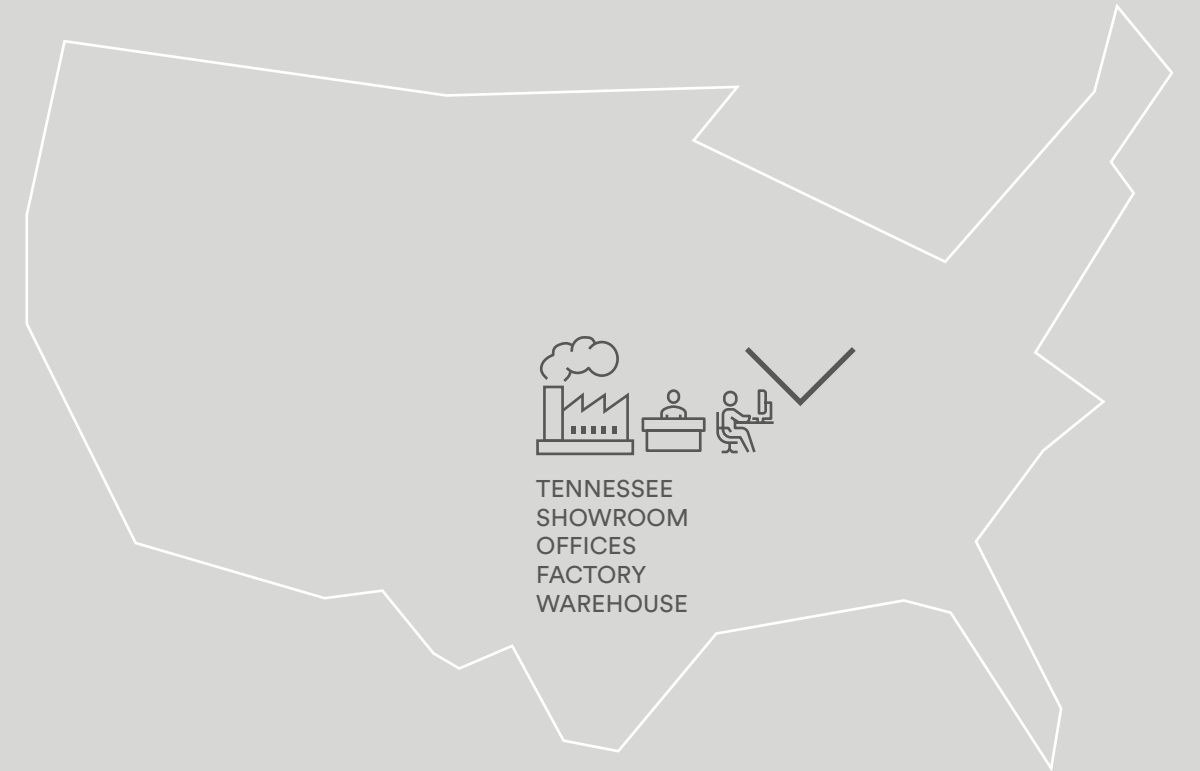

WHERE QUALITY MEETS DESIGN

The elegant design and carefully crafted details of Caesar USA products are totally integrated into a sound material with a superior performance. The excellent technical properties of Caesar USA porcelain stoneware acquire more value by virtue of aesthetic interpretations that across the years have become more and more diverse and refined, without losing the high quality standards that are part of the company's culture.

USA PRODUCTION PLANT

Caesar USA porcelain stoneware is manufactured in Tennessee, in a new cutting edge facility located in Mount Pleasant.

USA SHOWROOM

The showroom and sales offices of Caesar Ceramics USA are located in Brentwood, TN, 15 only minutes away from downtown Nashville. Over 4,300 square feet have been dedicated to showing Caesar's most popular lines in an inspiring and modern way. Architects, designers, builders, and distributors are invited to see the wide range of collections and colors available. Caesar USA's headquarters also includes sales and marketing offices, meeting rooms and comfortable environments for designers to explore the endless potential of Caesar porcelain stoneware.

ETHICS, TRUST, RESPONSIBILITY, ENVIRONMENT.

The Caesar company and staff share the same values of honesty, competence and respect for people and the environment. The brand's international certifications and reputation for making eco-friendly products have earned the trust of customers and designers for decades



The Health Product Declaration (HPD) Open Standard provides for the disclosure of product contents and potential associated human and environmental health hazards. By means of its declaration, Caesar USA adheres to the standard.

Caesar Ceramics USA is a member of US Green Building Council (USGBC). The LEED program, promoted by the USGBC, is the most widely used green building rating system in the world. Available for virtually all building, community and home project types, LEED provides a framework to create healthy, highly efficient and cost-saving green buildings.

SUSTAINABLE MIND

MAXIMUM CONCERN FOR THE ENVIRONMENT



FROM OUR PLANT....

The **brand new production facilities** in the USA are built in compliance with the most stringent standards in term of environmental protection, safety of workers and reduction of energy consumption.



TO YOUR PROJECT.

By choosing Caesar Ceramics USA, the end user will be sure to purchase **durable, safe and green floor and wall tiles**: being extremely durable, they do not call for any chemical treatment, varnish or special detergent. They do not release dust or other substances, even when subject to high pedestrian traffic.

INSPIRE AND BE INSPIRED

Caesar USA offers products inspired by the most diverse looks, drawing inspiration from natural materials such as wood stone and metal, but also from man-made materials such as concrete and other creative textures.



TAILOR MADE FOR YOUR STYLE

Caesar's versatile collections are designed to suit any style and personality. From contemporary to classic, the wide range of effects and colors can add character to any space.



SUPERIOR LOGISTICS AND CUSTOMERSERVICE

Tennessee is the home of all Caesar USA warehouses, production facilities and offices. From this hub, Caesar is able to organize personalized customer service and quick shipping in order to support customers and project managers in a timely and effective manner.



EVERLASTING BEAUTY

Caesar USA products are characterized by a discrete and balanced style: they are the expression of good taste and are materials created to last many years, despite changing fads and trends.



A COMPLETE RANGE

Colors, sizes, finishes: the Caesar USA ranges offers an exhaustive assortment of coverings for walls and floors but also a collection of slabs with a thickness of 3/4", especially made for outdoor installation.

THE EXCELLENCE OF CAESAR USA PORCELAIN STONEWARE

HEALTH AND SAFETY

Porcelain stoneware is the best choice for those who care about health and safety. Porcelain's non-porous surface remains hygienic over time by avoiding the absorption of unwanted germs and bacteria. It's completely hypoallergenic, VOC free and won't emit harmful substances. Due to porcelain's non-absorbent properties, it is safe to use aggressive detergents although it's easy to clean and resistant to staining.



ECO-FRIENDLY AND NONTOXIC: WON'T RELEASE HARMFUL SUBSTANCES



HYGIENIC AND SAFE



NO CHEMICAL WATERPROOFING AGENTS, PAINT, OR RESIN



EASY TO CLEAN AND STAIN RESISTANT

HEAT AND FIRE RESISTANCE

Porcelain stoneware is naturally fireproof, and won't burn in the event of a fire. Even in intense heat porcelain maintains its shape and never releases toxins into the atmosphere.



HEAT RESISTANT



FIRE RESISTANT



RESISTANT TO SUN DAMAGE AND COLOR FADING

VERSATILITY AND SUSTAINABILITY

The choice of an eco-sustainable, durable and versatile material for floors and walls means a lot of benefits for the environment. Caesar USA porcelain stoneware is produced with non-exhaustible, natural, raw materials, that are easy to install, and, at the end of its long life, it is easy and cheap to dispose of 100% recyclable.



EASY TO INSTALL



WATER AND DAMP RESISTANT



IDEAL FOR HEATED FLOORS

BEAUTY & DURABILITY

Porcelain tiles remain as beautiful as the first day even when they are exposed to different types of stress. They resist scratches and abrasions and are able to withstand heavy loads. This mean it is a material suitable for driveways and high traffic places.



LOAD BEARING AND STRESS RESISTANT



FROSTPROOF



SCRATCH AND ABRASION RESISTANT



THERMAL SHOCK RESISTANT



RESISTANT TO SMOG AND POLLUTION



RESISTANT TO HOUSEHOLD AND INDUSTRIAL CHEMICALS

INSPIRATIONS

STONE



ORIGIN
74

PATHWAY
82

PLACE
90

SELECT
114

STONEWAYS
124

WOOD



NATURE
66

REVIVE
98

WHISPER
148

DESIGN



BOND
14

COSMIX
22

CRETE
32

FOUNDRY26
42

GEMSTONE
50

LINK
58

RUN
106

STYLE
132

WAVES
140

OUTDOOR



AEXTRA20
156

BOND

— THE AESTHETIC FUSION OF TEXTILE CONCRETE

COLOR-BODY PORCELAIN TILES
RECTIFIED - MATTE FINISH

SILK

LEATHER

JUTE

WOOL



SIZES

24"x48"



24"x24"



12"x24"

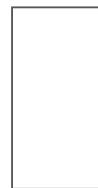

6"x24"



DECORS

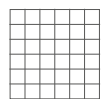

2"x2"
mosaic



2"x6.5"
stretch mosaic



Floor: Wool 24"x48"
Wall: Wool 6"x24", Mosaic Leather 2"x2"



Floor: Silk 24"x48"
Wall&Desk: Silk Mosaic 2"x2"



Floor: Jute 24"x48"
Wall: Jute stretch mosaic 2"x6.5"



Floor: Leather 24"x48"
Wall: Silk 24"x48", 12"x24", 6"x24"
Desk&niches: Nature Stave 24"x48"

SILK

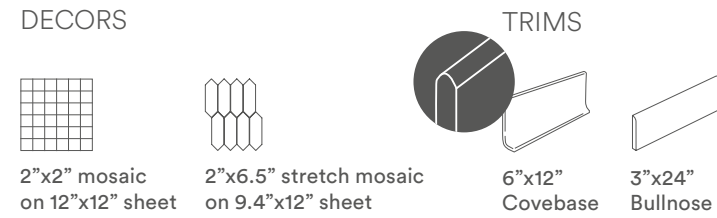

JUTE

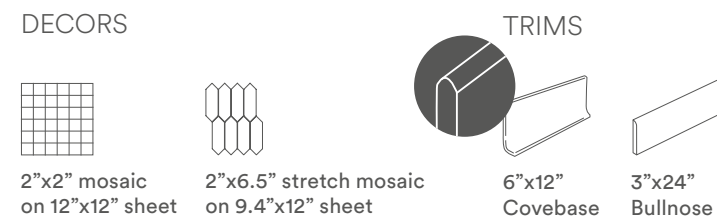

LEATHER

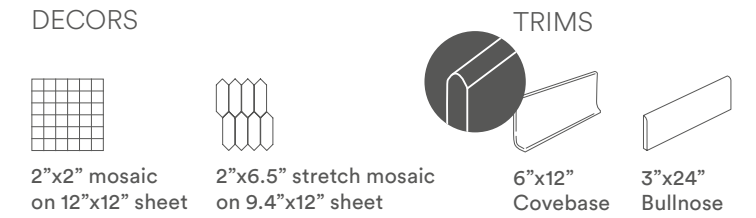

WOOL

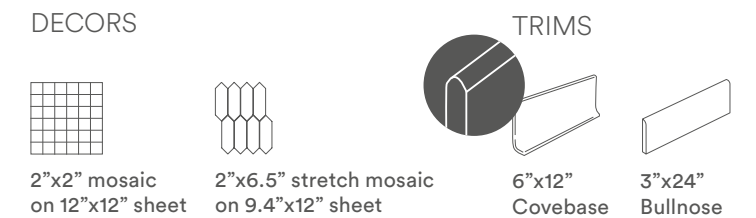

RANGE

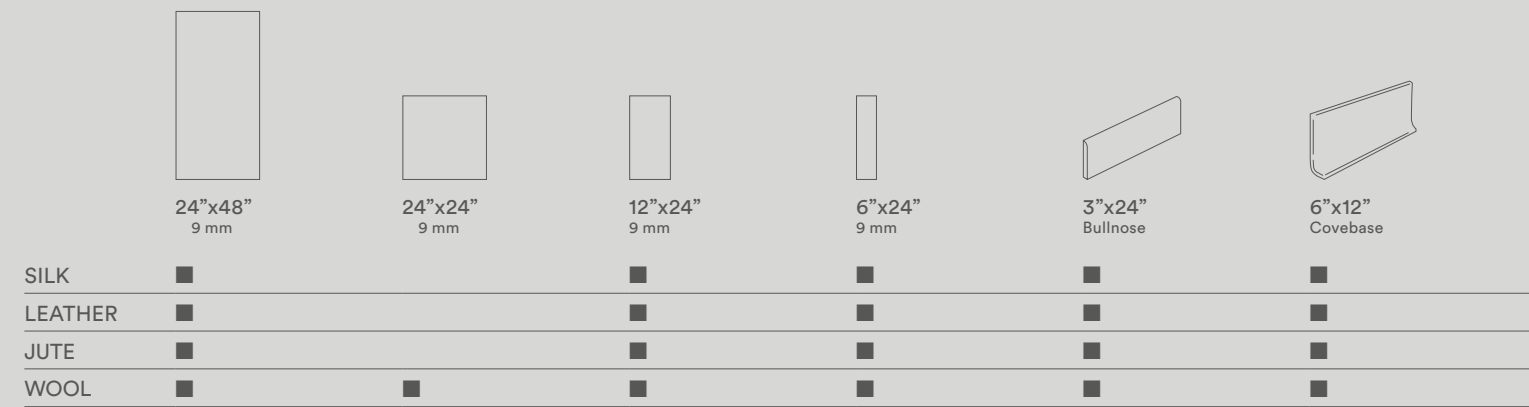

■ Rectified, squared, one caliber

Available in all colors

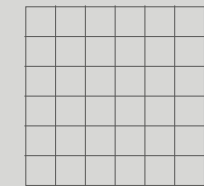

2"x2" mosaic on 12"x12" sheet

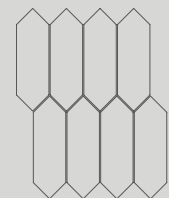

2"x6.5" stretch mosaic on 9.4"x12" sheet



V2 Slight Variation. Clearly distinguishable texture and/or pattern within similar colors.

All sizes are nominal. For actual size information please refer to page 177.

PACKAGING

Size	Box	Pallet								
Inches	Pcs	Surface (sqf)	Surface (sqm)	Weigth (lbs)	Weigth (kg)	Boxes	Surface (sqf)	Surface (sqm)	Weigth (lbs)	Weigth (kg)
24"x 48"	2	15.51	1.44	~62.81	~28.4	35	542.85	50.43	~2200	~997
24"x24"	3	11.63	1.08	~47.62	~21.6	40	465.00	43.2	~1904.77	~864
12"x24"	7	13.56	1.26	~55.56	~25.2	40	542.51	50.4	~2222.4	~1008
6"x24"	12	11.63	1.08	~47.62	~21.6	40	465.00	43.2	~1904.77	~864
2"x 2" Mosaic	10 sheets	9.69	0.9	~39.68	~18	36	348.75	32.4	~1428.58	~648
2"x 6.5" Stretch mosaic	5	3.23	0.30	~3.12	~5.95	60	139.80	18.00	~1787.20	~357

We recommend you a 2/3 mm grout joint to simplify the laying and optimize the naturalness of the final result. In order to favour the ordinary maintenance procedures, it is recommended to carry out an acid wash of the surface after 48 hours from grout filling using an acid agent specific for porcelain stoneware tiles.

Caesar Ceramics USA reserves the right to change the products presented in this catalogue at any time.

Tones of samples are indicative

For information about installation and cleaning of Caesar products, please consult our general catalogue or the website www.caesarceramicsusa.com. Color reproductions may vary from actual products. Caesar reserves the right to modify the products illustrated in this catalogue for reasons of production or to improve quality. Samples are purely indicative. Packaging and weights may vary for production reasons. Contact our sales department when ordering. In case of running pattern installation, Caesar recommends a maximum 33% offset. Caesar warrants that our products meet or exceed the requirements of ANSI, specification ANSI A137.1: 2012, as shown in our Tile Performance Data sheets.

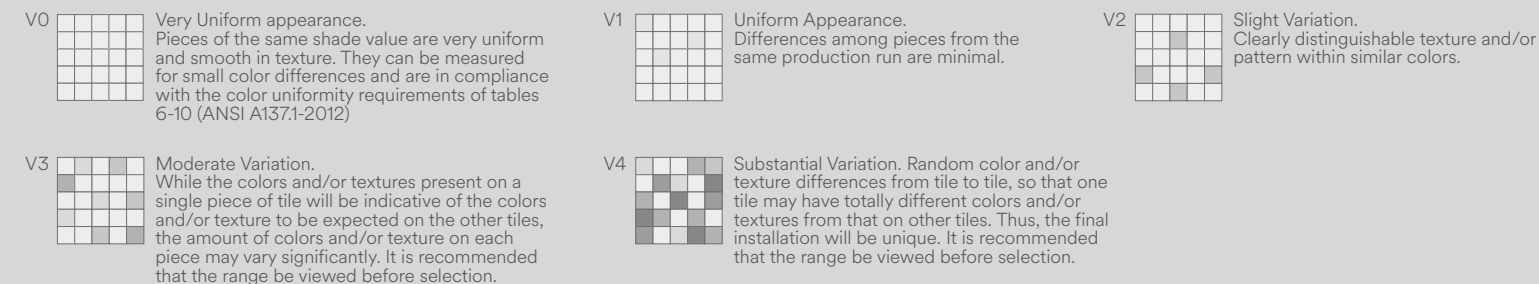

BOND TILE PERFORMANCE DATA

Color-body porcelain stoneware tiles are produced minimizing the color difference between the glaze and the body. Nevertheless, the design is visible only on the surface.



TECHNICAL FEATURE	METHOD	VALUE REQUIRED ANSI A 137.1	CAESAR AVERAGE VALUE
Facial dimension	ASTM C-499	± 0.25% or ± 0.03 in	
Wedging	ASTM C-502	± 0.25% or ± 0.03 in	
Warpage diagonal	ASTM C-485	± 0.4% or ± 0.07 in	In accordance to ANSI A 137.1
Warpage edge	ASTM C-485	± 0.4% or ± 0.05 in	
Thickness	ASTM C-499	RANGE: 0.040 inch max (1 mm)	In accordance to ANSI A 137.1
Water absorption	ASTM C-373	≤ 0.5%	Passed "impervious tiles" Class P1
Breaking strength	ASTM C-648	≥ 250 lbs (≥1113 N)	≥400 lbs
Freeze thaw	ASTM C-1026	No damages	In accordance
Chemical resistance	ASTM C-650	As reported	Unaffected
MOHS hardness			6
Dynamic Coefficient of Friction	ANSI A 326.3	Declare Classified	WET DOCF ≥0.42 Interior Wet

Average values referred to the last two years of production and related to the matte finish of the product. Values relate to the matte finish of the product and to tests carried out by certified external laboratories, whose results are available upon request. Be sure to use the same caliber tiles. Color reproductions may vary from actual products. * Due to the intrinsic nature of porcelain stoneware tiles, please note that the coefficient of friction may vary from one production lot to another. Caesar products can become slippery when wet. We recommend to always keep the surface dry.

COSMIX

— STELLAR DESIGN, BOUNDLESS POSSIBILITIES

COLOR-BODY PORCELAIN TILES
RECTIFIED - MATTE FINISH

VENUS

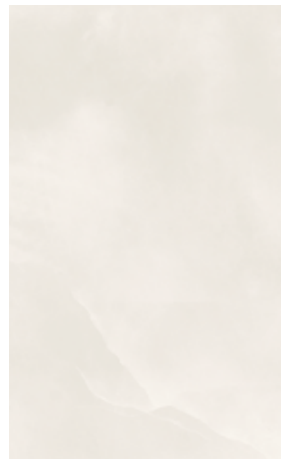

SATURN



MARS



MERCURY



JUPITER



SIZES

24"x48"



24"x24"



12"x24"



6"x24"



DECORS

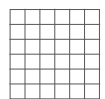

2"x2" mosaic
on 12"x12" sheet



4.4"x3.8" hexagon mosaic
on 11"x14" sheet



Floor: Venus 6"x24"
Wall: Venus mosaic 2"x2", Venus 24"x48", Jupiter 24"x48"



Floor: Mercury 24"x48", Venus 24"x48"
Wall: Mercury 24"x48"
Desk: Venus 2"x2" Mosaic



Floor: Saturn 24"x48"
Wall&Desk: Mercury mosaic 2"x2"



Floor: Mercury 24"x48"
Wall: Jupiter 6"x24", Jupiter 4.4"x3.8" hexagon mosaic

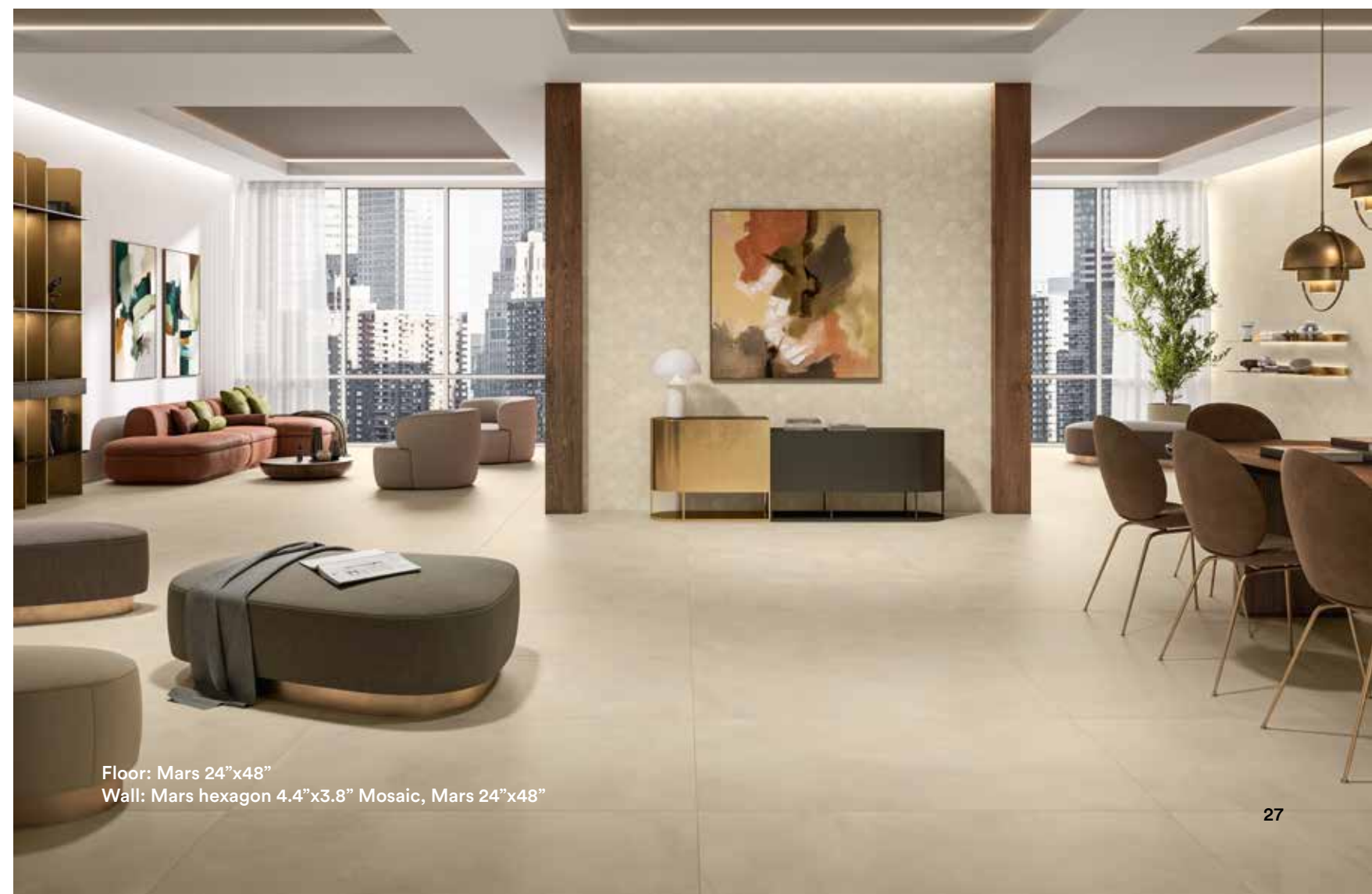

Floor: Mars 24"x48"
Wall: Mars hexagon 4.4"x3.8" Mosaic, Mars 24"x48"

MARS

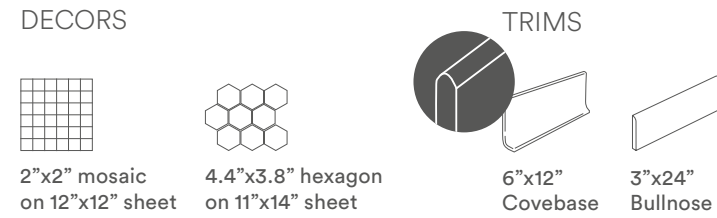

SATURN

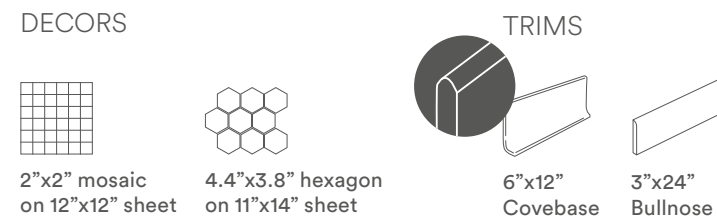
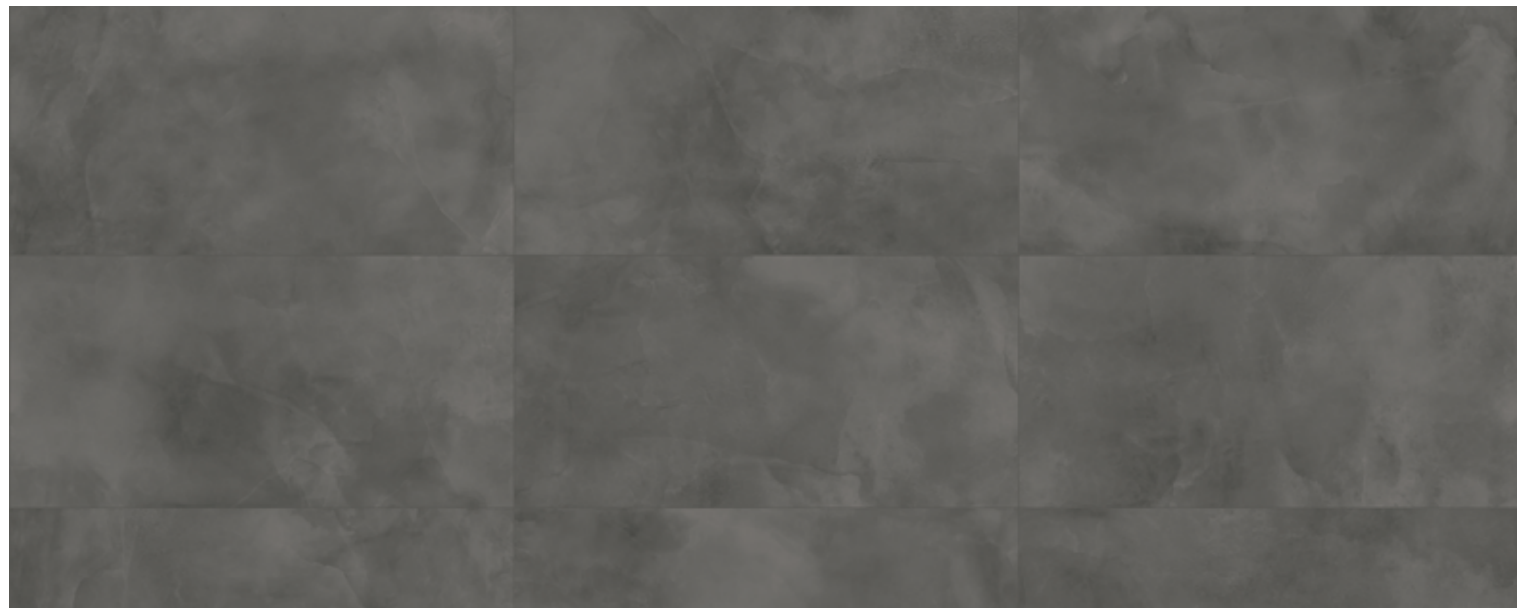

MERCURY

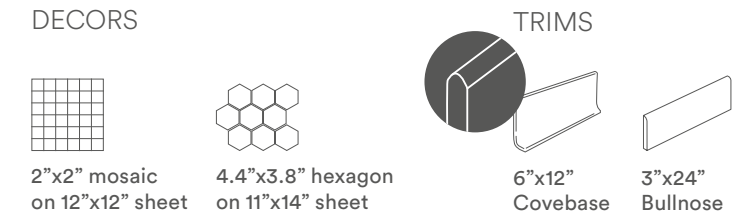
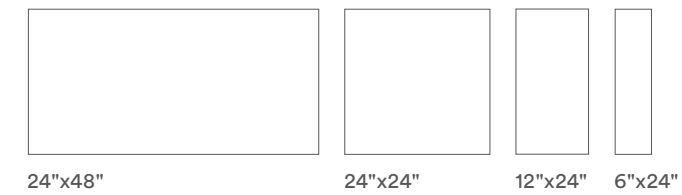

VENUS

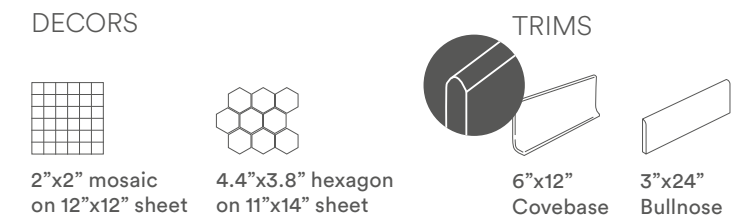
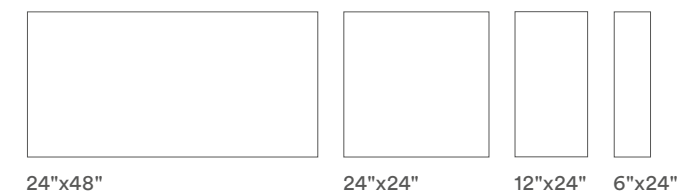
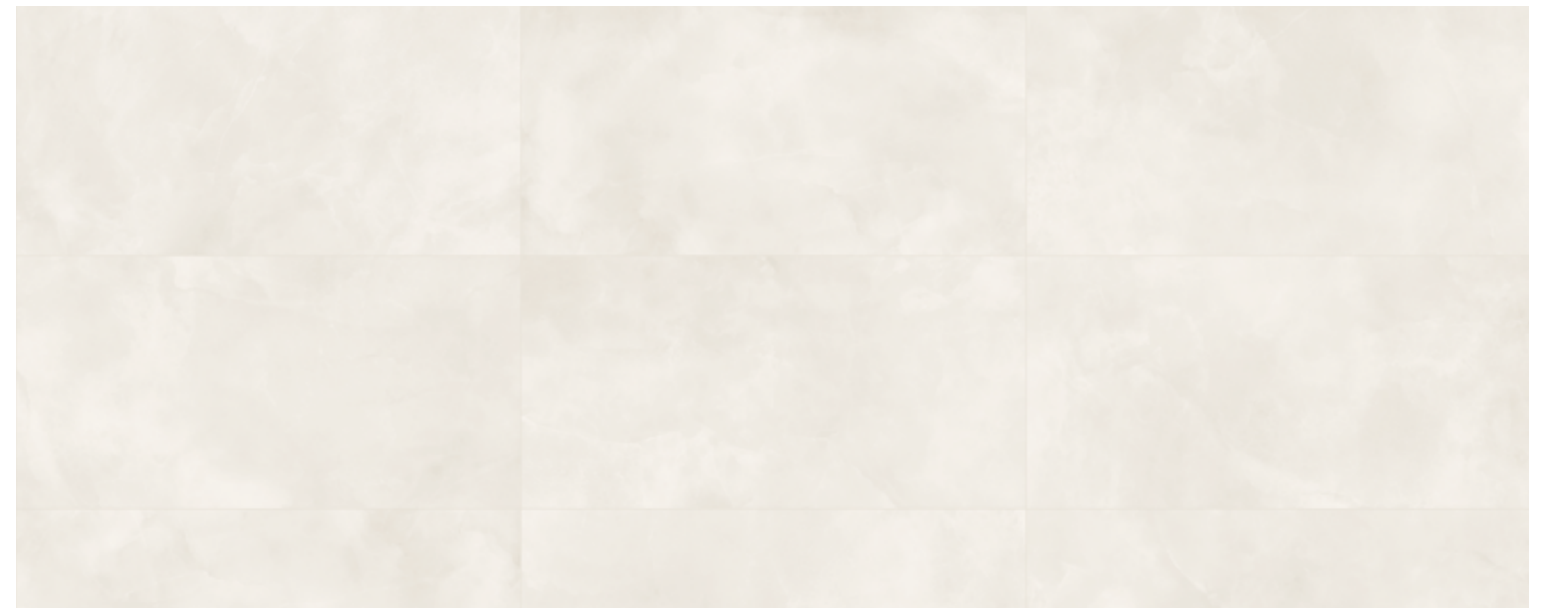

JUPITER



24"x48"



12"x24"



6"x24"

DECORS



2"x2" mosaic
on 12"x12" sheet



4.4"x3.8" hexagon
on 11"x14" sheet



TRIMS





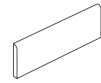

6"x12"
Covebase



3"x24"
Bullnose

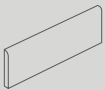
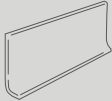

RANGE

						
	24"x48" 9 mm	24"x24" 9 mm	12"x24" 9mm	6"x24" 9mm	3"x24" Bullnose	6"x12" Covebase
JUPITER	■		■	■	■	■
MARS	■		■	■	■	■
MERCURY	■	■	■	■	■	■
SATURN	■		■	■	■	■
VENUS	■	■	■	■	■	■

■ Rectified, squared, one caliber

Available in all colors

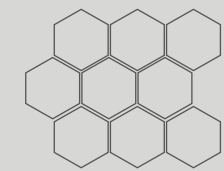

4.4"x3.8" hexagon
on 11"x14" sheet

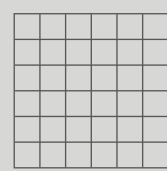

2"x2" mosaic
on 12"x12" sheet

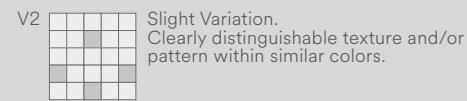

All sizes are nominal. For actual size
information please refer to page 177.

PACKAGING





Size	Box				Pallet					
	Pcs	Surface (sqf)	Surface (sqm)	Weigth (lbs)	Weigth (kg)	Boxes	Surface (sqf)	Surface (sqm)	Weigth (lbs)	Weigth (kg)
24"x 48"	2	15.51	1.44	~62.81	~28.4	35	542.85	50.43	~2200	~997
24"x 24"	3	11.63	1.08	~47.62	~21.6	40	465.00	43.2	~1904.77	~864
12"x 24"	7	13.56	1.26	~55.56	~25.2	40	542.51	50.4	~2222.24	~1008
6"x 24"	12	11.63	1.08	~47.62	~21.6	40	465.00	43.2	~1904.77	~864
2"x 2" Mosaic	10 sheets	9.69	0.9	~39.68	~18	36	348.75	32.4	~1428.58	~648
4.4"x3.8" Hexagon Mosaic	5 sheets	4.14	0.385	~ 16.77	~7.61	60	248.65	23.1	~1006.2	~456.6

We recommend you a 2/3 mm grout joint to simplify the laying and optimize the naturalness of the final result. In order to favour the ordinary maintenance procedures, it is recommended to carry out an acid wash of the surface after 48 hours from grout filling using an acid agent specific for porcelain stoneware tiles.

Caesar Ceramics USA reserves the right to change the products presented in this catalogue at any time.

Tones of samples are indicative











For information about installation and cleaning of Caesar products, please consult our general catalogue or the website www.caesarceramicsusa.com. Color reproductions may vary from actual products. Caesar reserves the right to modify the products illustrated in this catalogue for reasons of production or to improve quality. Samples are purely indicative. Packaging and weights may vary for production reasons. Contact our sales department when ordering. In case of running pattern installation, Caesar recommends a maximum 33% offset. Caesar warrants that our products meet or exceed the requirements of ANSI, specification ANSI A137.1: 2012, as shown in our Tile Performance Data sheets.

V0 	Very Uniform appearance. Pieces of the same shade value are very uniform and smooth in texture. They can be measured for small color differences and are in compliance with the color uniformity requirements of tables 6-10 (ANSI A137.1-2012)
V1 	Uniform Appearance. Differences among pieces from the same production run are minimal.
V2 	Slight Variation. Clearly distinguishable texture and/or pattern within similar colors.
V3 	Moderate Variation. While the colors and/or textures present on a single piece of tile will be indicative of the colors and/or texture to be expected on the other tiles, the amount of colors and/or texture on each piece may vary significantly. It is recommended that the range be viewed before selection.
V4 	Substantial Variation. Random color and/or texture differences from tile to tile, so that one tile may have totally different colors and/or textures from that on other tiles. Thus, the final installation will be unique. It is recommended that the range be viewed before selection.

COSMIX TILE PERFORMANCE DATA

Color-body porcelain stoneware tiles are produced minimizing the color difference between the glaze and the body. Nevertheless, the design is visible only on the surface.



TECHNICAL FEATURE	METHOD	VALUE REQUIRED ANSI A 137.1	CAESAR AVERAGE VALUE
 Facial dimension	ASTM C-499	± 0.25% or ± 0.03 in	In accordance to ANSI A 137.1
 Wedging	ASTM C-502	± 0.25% or ± 0.03 in	
 Warp page diagonal	ASTM C-485	± 0.4% or ± 0.07 in	
 Warp page edge	ASTM C-485	± 0.4% or ± 0.05 in	
 Thickness	ASTM C-499	RANGE: 0.040 inch max (1 mm)	In accordance to ANSI A 137.1
 Water absorption	ASTM C-373	≤ 0.5%	Passed "impervious tiles" Class P1
 Breaking strength	ASTM C-648	≥ 250 lbs (≥1113 N)	≥400 lbs
 Freeze thaw	ASTM C-1026	No damages	In accordance
 Chemical resistance	ASTM C-650	As reported	Unaffected
 MOHS hardness			6
 Dynamic Coefficient of Friction	ANSI A 326.3	Declare	WET DOCF ≥0.42
		Classified	Interior Wet

Average values referred to the last two years of production and related to the matte finish of the product. Values relate to the matte finish of the product and to tests carried out by certified external laboratories, whose results are available upon request. Be sure to use the same caliber tiles. Color reproductions may vary from actual products. * Due to the intrinsic nature of porcelain stoneware tiles, please note that the coefficient of friction may vary from one production lot to another. Caesar products can become slippery when wet. We recommend to always keep the surface dry.

CRETE

— CRAFTED BY TRADITION, SHAPED BY DESIGN

COLOR-BODY PORCELAIN TILES
RECTIFIED - MATTE FINISH

AVORIO



MATERIA



UMBRA



ARGILLA



TERRA



SIZES

24"x48"



12"x24"



6"x24"



6"x12"



DECORS

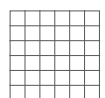

2"x2" mosaic
on 12"x12" sheet

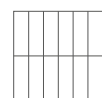

2"x6" mosaic
on 12"x12" sheet



12"x24"
3d motion



design CRETE

Floor: Terra 6"x24"
Walkway: Terra 24"x48"



Floor: Argilla 24"x48"
Wall: Argilla 12"x24" - Avorio 2"x6" Mosaic



Floor: Umbra 6"x24"
Wall: Materia 3d Motion 12"x24"
Bed headboard: Umbra 2"x6" Mosaic

design CRETE



Floor: Materia 12"x24" - 24"x48"
Wall: Terra 12"x24" - Materia 12"x24"
Desk: Terra 2"x6" Mosaic



Floor: Avorio 24"x48"
Walkway: Terra 6"x12"
Wall: Terra 12"x24" - Avorio 2"x2" Mosaic

AVORIO

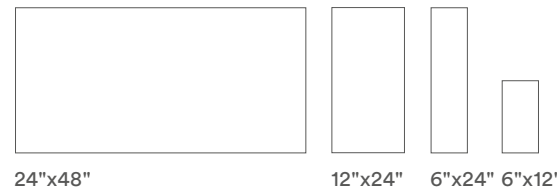

DECORS

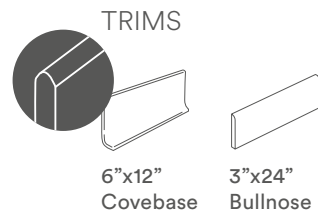
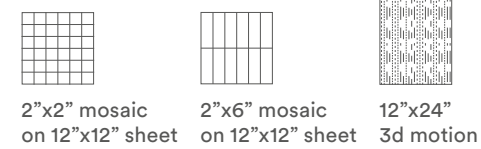

MATERIA

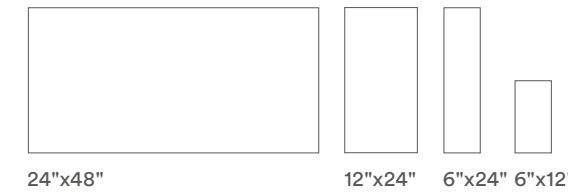

DECORS

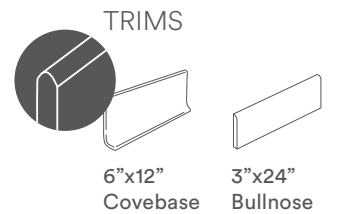
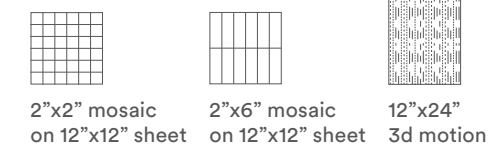

TERRA

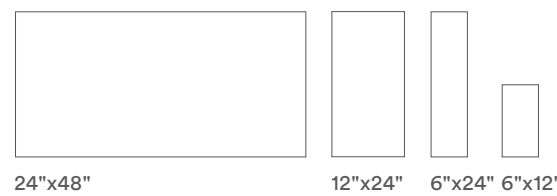

DECORS

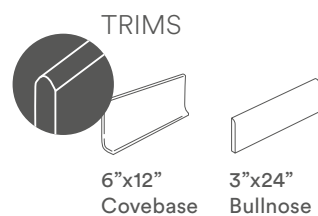
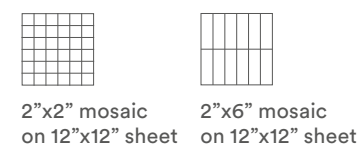

UMBRA

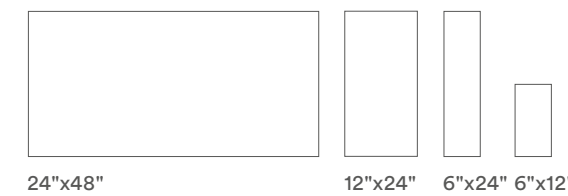

DECORS

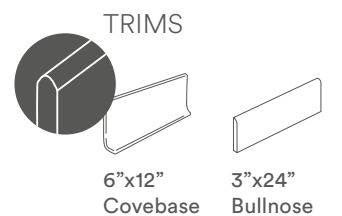
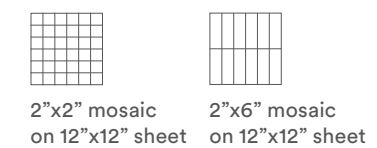

ARGILLA



24"x48"



12"x24"



6"x24"



6"x12"

DECORS



2"x2" mosaic
on 12"x12" sheet



2"x6" mosaic
on 12"x12" sheet

TRIMS



6"x12"
Covebase







3"x24"
Bullnose



Wall: Argilla 2"x6" Mosaic on 12"x12" sheet

RANGE

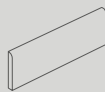
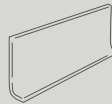
						
	24"x48" 9 mm	12"x24" 9 mm	6"x24" 9 mm	6"x12" 9 mm	3"x24" Bullnose	6"x12" Covebase
AVORIO	■	■	■	■	■	■
MATERIA	■	■	■	■	■	■
UMBRA	■	■	■	■	■	■
ARGILLA	■	■	■	■	■	■
TERRA	■	■	■	■	■	■

■ Rectified, squared, one caliber

Available in all colors

Available Avorio/Materia

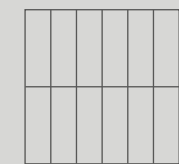

2"x6" mosaic on 12"x12" sheet

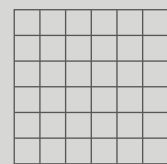

2"x2" mosaic on 12"x12" sheet

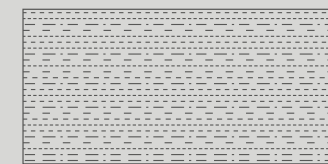

12"x24" 3d motion

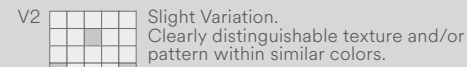

All sizes are nominal. For actual size information please refer to page 177.

PACKAGING





Size	Box					Pallet					
	Inches	Pcs	Surface (sqf)	Surface (sqm)	Weight (lbs)	Weight (kg)	Boxes	Surface (sqf)	Surface (sqm)	Weight (lbs)	Weight (kg)
24"x 48"	24	2	15.51	1.44	~62.81	~28.4	35	542.85	50.43	~2200	~997
24"x 24"	24	3	11.63	1.08	~47.62	~21.6	40	465.00	43.2	~1904.77	~864
12"x 24"	12	7	13.56	1.26	~55.56	~25.2	40	542.51	50.4	~2222.24	~1008
6"x 24"	6	12	11.63	1.08	~47.62	~21.6	40	465.00	43.2	~1904.77	~864
6"x 12"	6	20	9.69	0.9	~39.68	~18	60	581.25	54	~2380.97	~1080
2"x 2" Mosaic	2	10 sheets	9.69	0.9	~39.68	~18	36	348.75	32.4	~1428.58	~648
2"x 6" Mosaic	2	10 sheets	9.69	0.9	~39.68	~18	36	348.75	32.4	~1428.58	~648
12"x 24" 3d motion	12	7	13.56	1.26	~55.56	~25.2	40	542.51	50.4	~2222.24	~1008

We recommend you a 2/3 mm grout joint to simplify the laying and optimize the naturalness of the final result. In order to favour the ordinary maintenance procedures, it is recommended to carry out an acid wash of the surface after 48 hours from grout filling using an acid agent specific for porcelain stoneware tiles.

Caesar Ceramics USA reserves the right to change the products presented in this catalogue at any time.

Tones of samples are indicative











For information about installation and cleaning of Caesar products, please consult our general catalogue or the website www.caesarceramicsusa.com. Color reproductions may vary from actual products. Caesar reserves the right to modify the products illustrated in this catalogue for reasons of production or to improve quality. Samples are purely indicative. Packaging and weights may vary for production reasons. Contact our sales department when ordering. In case of running pattern installation, Caesar recommends a maximum 33% offset. Caesar warrants that our products meet or exceed the requirements of ANSI, specification ANSI A137.1: 2012, as shown in our Tile Performance Data sheets.

V0		Very Uniform appearance. Pieces of the same shade value are very uniform and smooth in texture. They can be measured for small color differences and are in compliance with the color uniformity requirements of tables 6-10 (ANSI A137.1-2012)
V1		Uniform Appearance. Differences among pieces from the same production run are minimal.
V2		Slight Variation. Clearly distinguishable texture and/or pattern within similar colors.
V3		Moderate Variation. While the colors and/or textures present on a single piece of tile will be indicative of the colors and/or texture to be expected on the other tiles, the amount of colors and/or texture on each piece may vary significantly. It is recommended that the range be viewed before selection.
V4		Substantial Variation. Random color and/or texture differences from tile to tile, so that one tile may have totally different colors and/or textures from that on other tiles. Thus, the final installation will be unique. It is recommended that the range be viewed before selection.

CRETE TILE PERFORMANCE DATA

Color-body porcelain stoneware tiles are produced minimizing the color difference between the glaze and the body. Nevertheless, the design is visible only on the surface.



TECHNICAL FEATURE	METHOD	VALUE REQUIRED ANSI A 137.1	CAESAR AVERAGE VALUE
 Facial dimension	ASTM C-499	± 0.25% or ± 0.03 in	
 Wedging	ASTM C-502	± 0.25% or ± 0.03 in	
 Warpage diagonal	ASTM C-485	± 0.4% or ± 0.07 in	In accordance to ANSI A 137.1
 Warpage edge	ASTM C-485	± 0.4% or ± 0.05 in	
 Thickness	ASTM C-499	RANGE: 0.040 inch max (1 mm)	In accordance to ANSI A 137.1
 Water absorption	ASTM C-373	≤ 0.5%	Passed "impervious tiles" Class P1
 Breaking strength	ASTM C-648	≥ 250 lbs (≥1113 N)	≥400 lbs
 Freeze thaw	ASTM C-1026	No damages	In accordance
 Chemical resistance	ASTM C-650	As reported	Unaffected
 MOHS hardness			6
 Dynamic Coefficient of Friction	ANSI A 326.3	Declare Classified	WET DOCF ≥0.42 Interior Wet

Average values referred to the last two years of production and related to the matte finish of the product. Values relate to the matte finish of the product and to tests carried out by certified external laboratories, whose results are available upon request. Be sure to use the same caliber tiles. Color reproductions may vary from actual products. * Due to the intrinsic nature of porcelain stoneware tiles, please note that the coefficient of friction may vary from one production lot to another. Caesar products can become slippery when wet. We recommend to always keep the surface dry.

FOUNDRY26

— MAGNETIC APPEAL

COLOR-BODY PORCELAIN TILES
RECTIFIED - MATTE FINISH

ZINC



ALLOY



OXIDE



RAIL



SIZES

12"x24"



DECORS

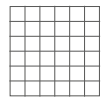

2"x2" mosaic
on 12"x12" sheet

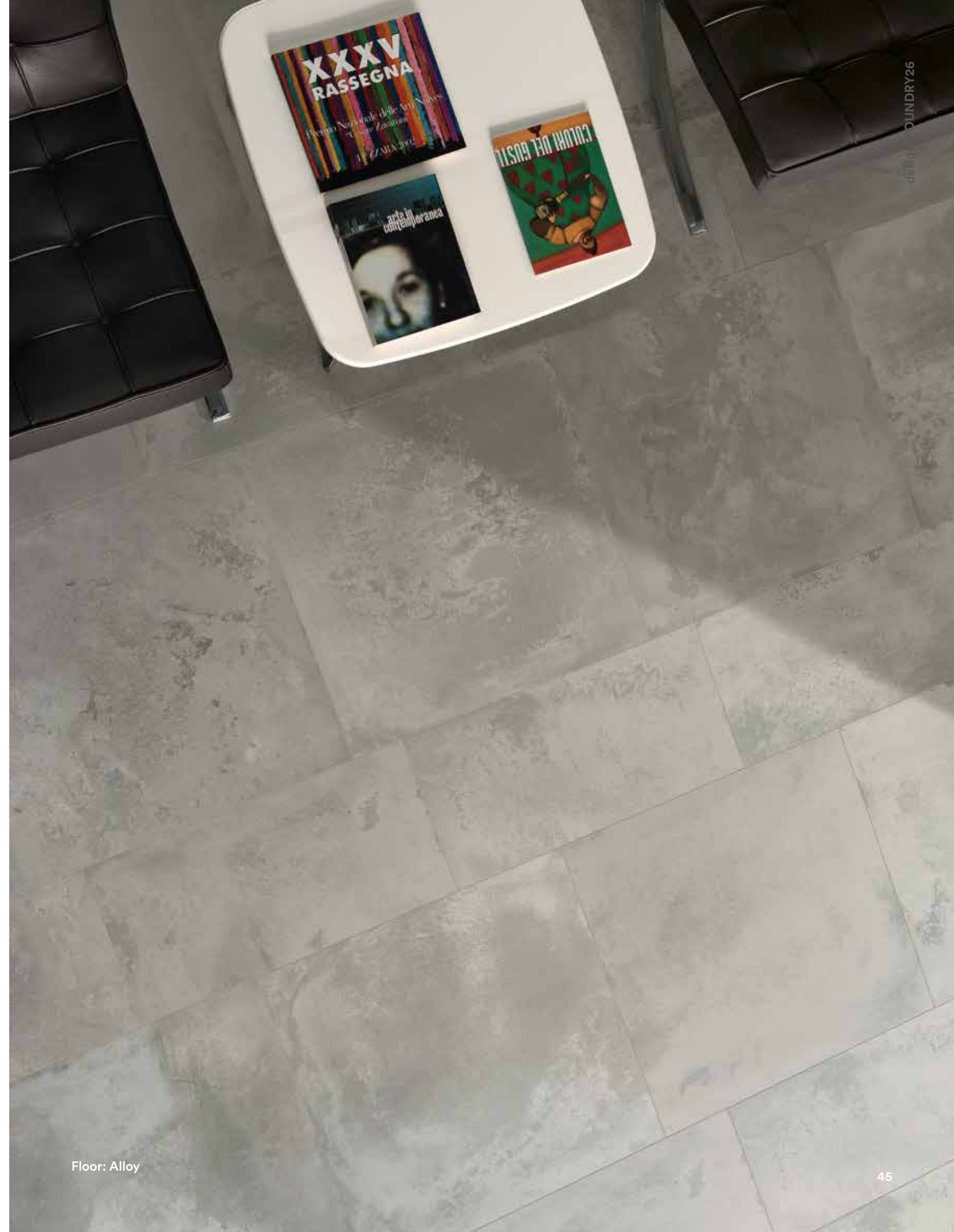

Floor: Alloy



Wall: Zinc 12"x24"



Floor: Rail 24"x24"
Wall: Zinc 12"x24"

design FOUNDRY26



Wall: Zinc 12"x24"



Floor: Alloy 12"x24", 24"x24"
Wall: Alloy 12"x24"

ZINC

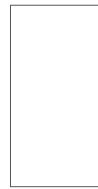

12"x24"

DECORS

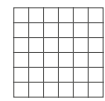

2"x2" mosaic
on 12"x12" sheet

TRIMS

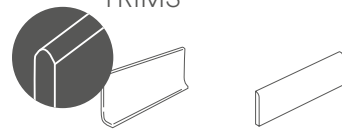

6"x12"
Covebase

3"x24"
Bullnose

ALLOY

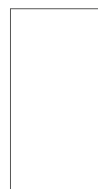

12"x24"

DECORS

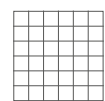

2"x2" mosaic
on 12"x12" sheet

TRIMS



6"x12"
Covebase

3"x24"
Bullnose

OXIDE



12"x24"

DECORS

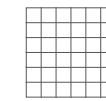

2"x2" mosaic
on 12"x12" sheet

TRIMS



6"x12"
Covebase

3"x24"
Bullnose

RAIL

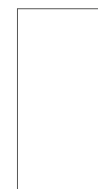

12"x24"

DECORS

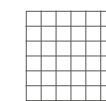

2"x2" mosaic
on 12"x12" sheet

TRIMS



6"x12"
Covebase

3"x24"
Bullnose

RANGE



ZINC	●	●	●
ALLOY	●	●	●
OXIDE	●	●	●
RAIL	●	●	●

● Matte, rectified, squared, one caliber

Available in all colors

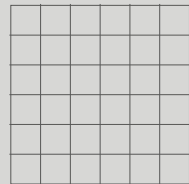

2"x2" mosaic on 12"x12" sheet

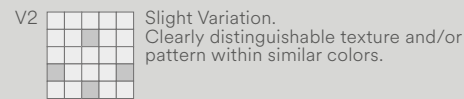

V2 Slight Variation. Clearly distinguishable texture and/or pattern within similar colors.

All sizes are nominal. For actual size information please refer to page 177.

PACKAGING

Size	Box		Pallet							
	Pcs	Surface (sqf)	Surface (sqm)	Weigth (lbs)	Weigth (kg)	Boxes	Surface (sqf)	Surface (sqm)	Weigth (lbs)	Weigth (kg)
12"x24"	7	13.56	1.26	~55.56	~25.2	40	542.51	50.4	~2222.4	~1008
2"x 2" Mosaic	10 sheets	9.69	0.9	~39.68	~18	36	348.75	32.4	~1428.6	~648

We recommend you a 2/3 mm grout joint to simplify the laying and optimize the naturalness of the final result. In order to favour the ordinary maintenance procedures, it is recommended to carry out an acid wash of the surface after 48 hours from grout filling using an acid agent specific for porcelain stoneware tiles.

Caesar Ceramics USA reserves the right to change the products presented in this catalogue at any time.

Tones of samples are indicative

For information about installation and cleaning of Caesar products, please consult our general catalogue or the website www.caesarceramicsusa.com. Color reproductions may vary from actual products. Caesar reserves the right to modify the products illustrated in this catalogue for reasons of production or to improve quality. Samples are purely indicative. Packaging and weights may vary for production reasons. Contact our sales department when ordering. In case of running pattern installation, Caesar recommends a maximum 33% offset. Caesar warrants that our products meet or exceed the requirements of ANSI, specification ANSI A137.1: 2012, as shown in our Tile Performance Data sheets.

V0 Very Uniform appearance. Pieces of the same shade value are very uniform and smooth in texture. They can be measured for small color differences and are in compliance with the color uniformity requirements of tables 6-10 (ANSI A137.1-2012)	V1 Uniform Appearance. Differences among pieces from the same production run are minimal.	V2 Slight Variation. Clearly distinguishable texture and/or pattern within similar colors.
V3 Moderate Variation. While the colors and/or textures present on a single piece of tile will be indicative of the colors and/or texture to be expected on the other tiles, the amount of colors and/or texture on each piece may vary significantly. It is recommended that the range be viewed before selection.	V4 Substantial Variation. Random color and/or texture differences from tile to tile, so that one tile may have totally different colors and/or textures from that on other tiles. Thus, the final installation will be unique. It is recommended that the range be viewed before selection.	

FOUNDRY26 TILE PERFORMANCE DATA

Color-body porcelain stoneware tiles are produced minimizing the color difference between the glaze and the body. Nevertheless, the design is visible only on the surface.



TECHNICAL FEATURE	METHOD	VALUE REQUIRED ANSI A 137.1	CAESAR AVERAGE VALUE
Facial dimension	ASTM C-499	± 0.25% or ± 0.03 in	
Wedging	ASTM C-502	± 0.25% or ± 0.03 in	
Warp page diagonal	ASTM C-485	± 0.4% or ± 0.07 in	In accordance to ANSI A 137.1
Warp page edge	ASTM C-485	± 0.4% or ± 0.05 in	
Thickness	ASTM C-499	RANGE: 0.040 inch max (1 mm)	In accordance to ANSI A 137.1
Water absorption	ASTM C-373	≤ 0.5%	Passed "impervious tiles" Class P1
Breaking strength	ASTM C-648	≥ 250 lbs (≥1113 N)	≥400 lbs
Freeze thaw	ASTM C-1026	No damages	In accordance
Chemical resistance	ASTM C-650	As reported	Unaffected
MOHS hardness			6
Dynamic Coefficient of Friction	ANSI A 326.3	Declare Classified	WET DOCF ≥0.42 Interior Wet

Average values referred to the last two years of production and related to the matte finish of the product. Values relate to the matte finish of the product and to tests carried out by certified external laboratories, whose results are available upon request. Be sure to use the same caliber tiles. Color reproductions may vary from actual products. * Due to the intrinsic nature of porcelain stoneware tiles, please note that the coefficient of friction may vary from one production lot to another. Caesar products can become slippery when wet. We recommend to always keep the surface dry.

GEMSTONE

— PRECIOSLY CRAFTED, NATURALLY CAPTIVATING

COLOR-BODY PORCELAIN TILES
RECTIFIED - MATTE FINISH

PEARL



STAR



BASALT



OBSIDIAN



SIZES

24"x48"



24"x24"



12"x24"

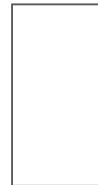

6"x24"



DECORS

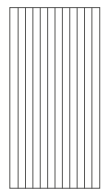

stave scored
on 12"x24" sheet

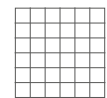

2"x2" mosaic
on 12"x12" sheet



3"x3.5" hexagon
on 11"x12" sheet



1.3"x3.8" herringbone
on 12"x14.5" sheet

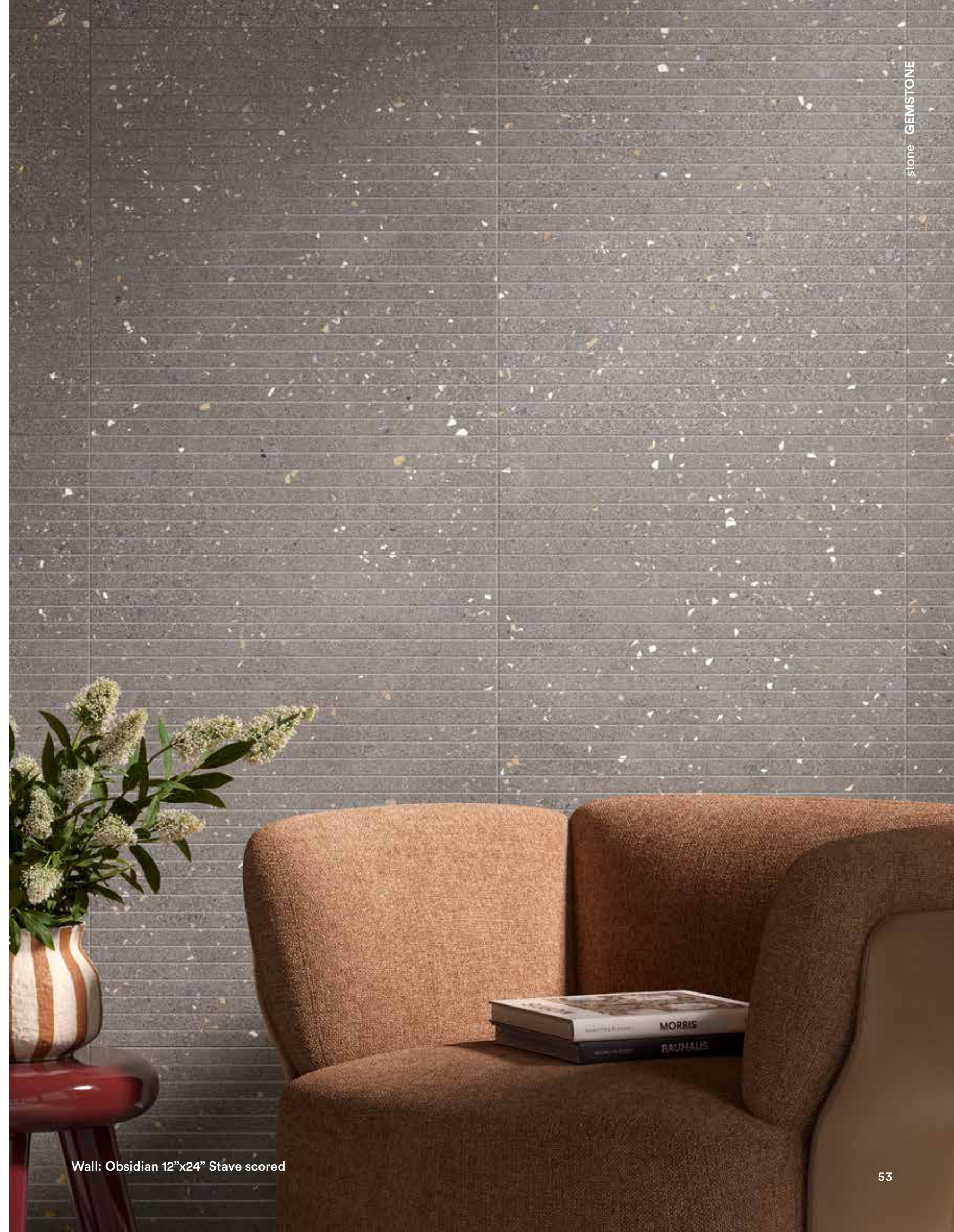

Wall: Obsidian 12"x24" Stave scored



Wall: Obsidian 24"x48"
 Floor: Pearl 24"x48"
 Desk: Pearl 3"x3.5" Hexagon



Floor: Basalt 24"x24" - Obsidian 6"x24"
 Wall&Desk: Pearl 2"x2" Mosaic

stone GEMSTONE



Floor: Star 24"x48"
 Wall: Star 24"x48" - Obsidian 3"x3.5" Hexagon



Wall: Obsidian 3"x3.5" Hexagon
 Floor: Obsidian 6"x24" - Pearl 6"x24"

PEARL

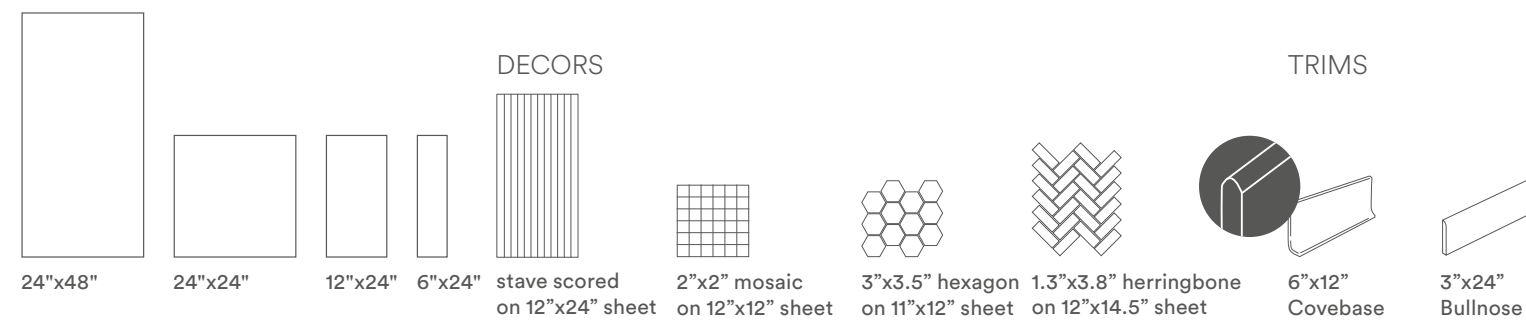

STAR

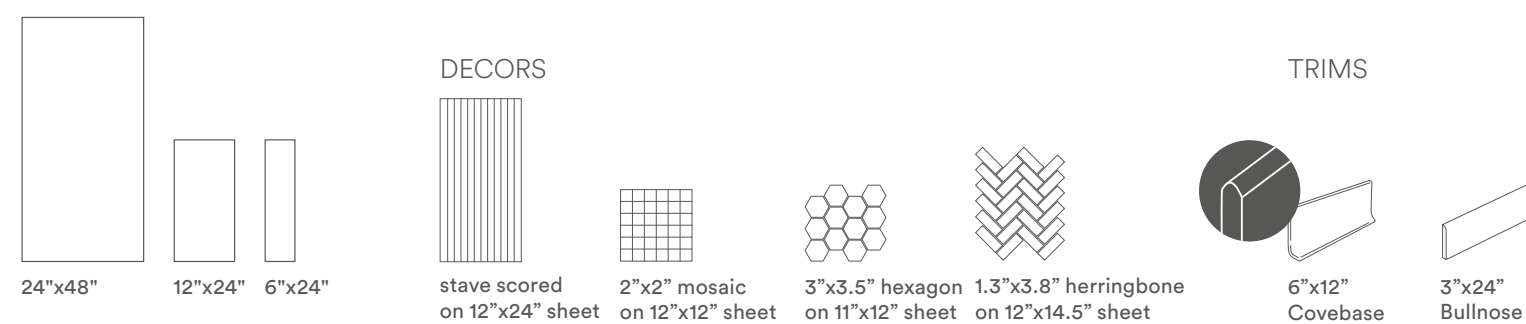



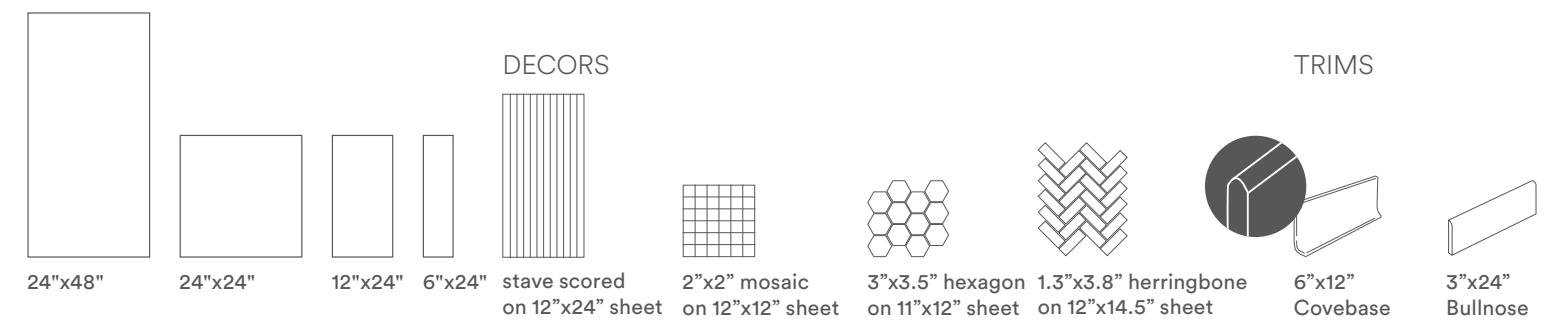

BASALT

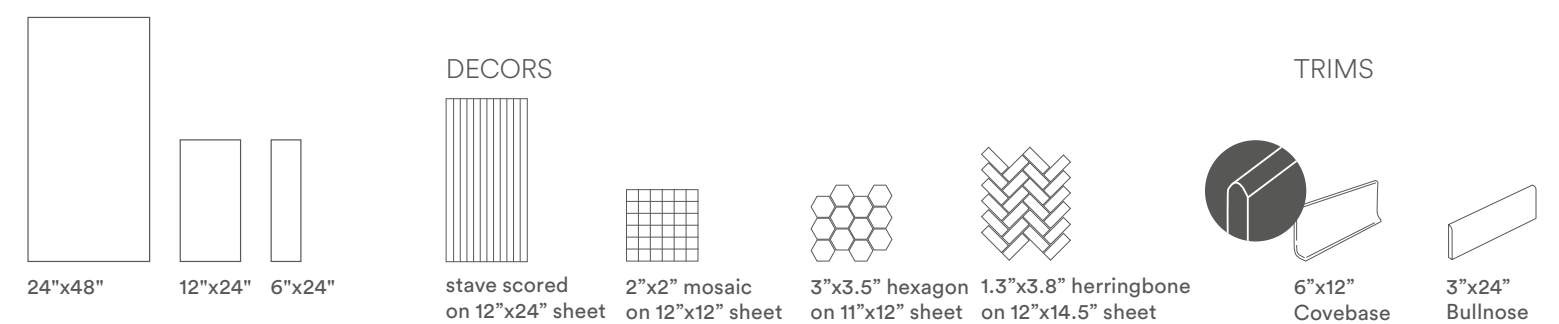

OBSIDIAN

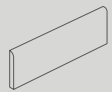
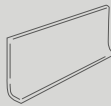

RANGE

						
	24"x48" 9 mm	24"x24" 9 mm	12"x24" 9 mm	6"x24" 9 mm	3"x24" Bullnose	6"x12" Covebase
PEARL	●	●	●	●	●	●
STAR	●		●	●	●	●
BASALT	●	●	●	●	●	●
OBSIDIAN	●		●	●	●	●

● Matte, rectified, squared, one caliber

Available in all colors



stave scored
on 12"x24" sheet

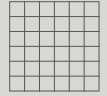

2"x2" mosaic
on 12"x12" sheet



3"x3.5" hexagon
on 11"x12" sheet



1.3"x3.8" herringbone
on 12"x14.5" sheet

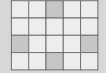

V2
Slight Variation.
Clearly distinguishable texture and/or
pattern within similar colors.

All sizes are nominal. For actual size information please refer to page 177.

PACKAGING

Size	Box		Pallet								
	Inches	Pcs	Surface (sqf)	Surface (sqm)	Weight (lbs)	Weight (kg)	Boxes	Surface (sqf)	Surface (sqm)	Weight (lbs)	Weight (kg)
24"x48"		2	15.51	144	~62.81	~28.4	35	542.85	50.43	~2200	~997
24"x24"		3	11.63	1.08	~47.62	~21.6	40	465	43.2	~1904.77	~864
12"x24"		7	13.56	1.26	~55.56	~25.2	40	542.51	50.4	~2222.4	~1008
6"x24"		12	11.63	1.08	~47.62	~21.6	40	465	43.2	~1904.77	~864
2"x2" mosaic		10 sheets	9.69	0.9	~39.68	~18	36	348.75	32.4	~1428.58	~648
3"x3.5" hexagon		10 sheets	8.93	0.83	~36.60	~16.6	36	321.48	29.88	~1317.6	~597.6
1.3"x3.8" Herringbone		7 sheets	6.46	0.6	~26.45	~12	36	232.56	21.6	~952.20	~432
12" x 24" Stave Scored		10 sheets	9.69	0.9	~39.68	~18	36	348.75	32.4	~1428.58	~648

We recommend you a 2/3 mm grout joint to simplify the laying and optimize the naturalness of the final result. In order to favour the ordinary maintenance procedures, it is recommended to carry out an acid wash of the surface after 48 hours from grout filling using an acid agent specific for porcelain stoneware tiles.

Caesar Ceramics USA reserves the right to change the products presented in this catalogue at any time.

Tones of samples are indicative

For information about installation and cleaning of Caesar products, please consult our general catalogue or the website www.caesarceramicsusa.com. Color reproductions may vary from actual products. Caesar reserves the right to modify the products illustrated in this catalogue for reasons of production or to improve quality. Samples are purely indicative. Packaging and weights may vary for production reasons. Contact our sales department when ordering. In case of running pattern installation, Caesar recommends a maximum 33% offset. Caesar warrants that our products meet or exceed the requirements of ANSI, specification ANSI A137.1: 2012, as shown in our Tile Performance Data sheets.

V0  Very Uniform appearance. Pieces of the same shade value are very uniform and smooth in texture. They can be measured for small color differences and are in compliance with the color uniformity requirements of tables 6-10 (ANSI A137.1-2012)

V1  Uniform Appearance. Differences among pieces from the same production run are minimal.

V2  Slight Variation. Clearly distinguishable texture and/or pattern within similar colors.



V3  Moderate Variation. While the colors and/or textures present on a single piece of tile will be indicative of the colors and/or texture to be expected on the other tiles, the amount of colors and/or texture on each piece may vary significantly. It is recommended that the range be viewed before selection.

V4  Substantial Variation. Random color and/or texture differences from tile to tile, so that one tile may have totally different colors and/or textures from that on other tiles. Thus, the final installation will be unique. It is recommended that the range be viewed before selection.

GEMSTONE TILE PERFORMANCE DATA

Color-body porcelain stoneware tiles are produced minimizing the color difference between the glaze and the body. Nevertheless, the design is visible only on the surface.



TECHNICAL FEATURE	METHOD	VALUE REQUIRED ANSI A 137.1	CAESAR AVERAGE VALUE
 Facial dimension	ASTM C-499	± 0.25% or ± 0.03 in	
 Wedging	ASTM C-502	± 0.25% or ± 0.03 in	In accordance to ANSI A 137.1
 Warpage diagonal	ASTM C-485	± 0.4% or ± 0.07 in	
 Warpage edge	ASTM C-485	± 0.4% or ± 0.05 in	
 Thickness	ASTM C-499	RANGE: 0.040 inch max (1 mm)	In accordance to ANSI A 137.1
 Water absorption	ASTM C-373	≤ 0.5%	Passed "impervious tiles" Class P1
 Breaking strength	ASTM C-648	≥ 250 lbs (≥1113 N)	≥400 lbs
 Freeze thaw	ASTM C-1026	No damages	In accordance
 Chemical resistance	ASTM C-650	As reported	Unaffected
 MOHS hardness			6
 Dynamic Coefficient of Friction	ANSI A 326.3	Declare	WET DOCF ≥0.42
		Classified	Interior Wet

Average values referred to the last two years of production and related to the matte finish of the product. Values relate to the matte finish of the product and to tests carried out by certified external laboratories, whose results are available upon request. Be sure to use the same caliber tiles. Color reproductions may vary from actual products. * Due to the intrinsic nature of porcelain stoneware tiles, please note that the coefficient of friction may vary from one production lot to another. Caesar products can become slippery when wet. We recommend to always keep the surface dry.

LINK

— CONCRETE VERSATILITY STONE APPEAL

COLOR-BODY PORCELAIN TILES
RECTIFIED - MATTE FINISH



SIZES

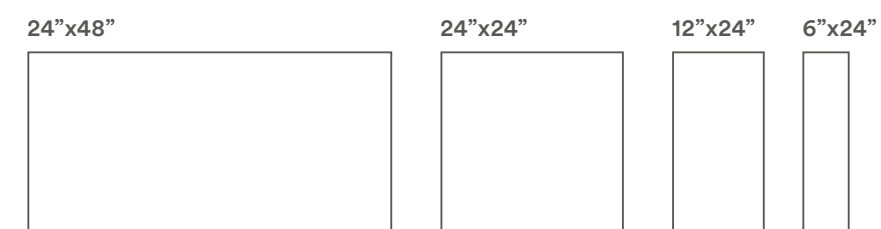

DECORS

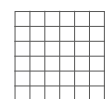

2"x2" mosaic
on 12"x12" sheet



Wall: Chain 12"x24"
Floor: Chain 24"x24"



Wall: Bolt 24"x24"
 Counter: Hook 12"x24", Whisper Sand 8"x40"
 Floor: Bolt 24"x48"



Wall: Whisper Forest 8"x40"
 Mix Color: Tie Bolt Chain Hook 24"x48" - 24"x24"
 Floor: Chain 24"x48", Fuse 12"x12"



Wall: Hook 12"x24"
 Floor: Tie 12"x24", Place Rust Textured 24"x24"

TIE

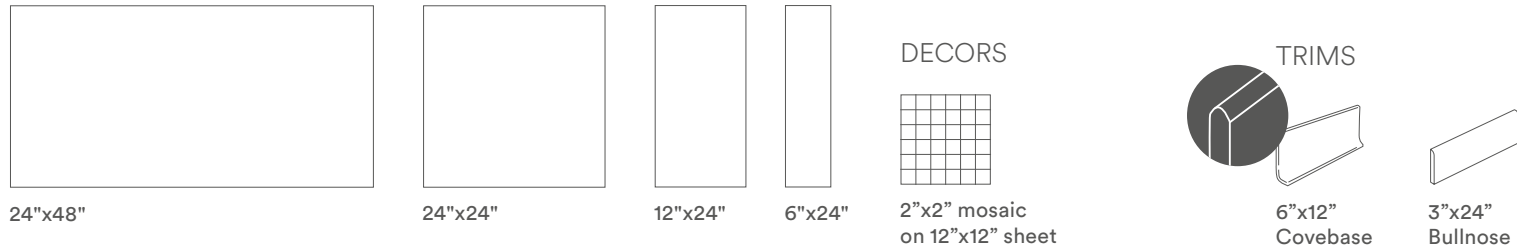

CHAIN

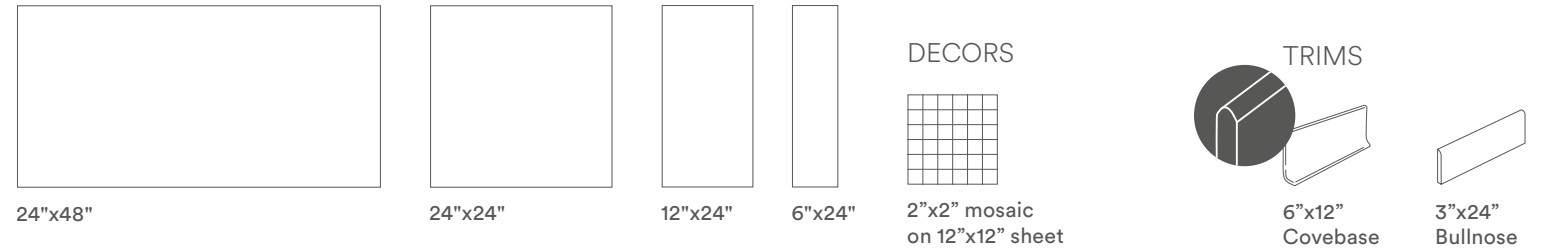

BOLT

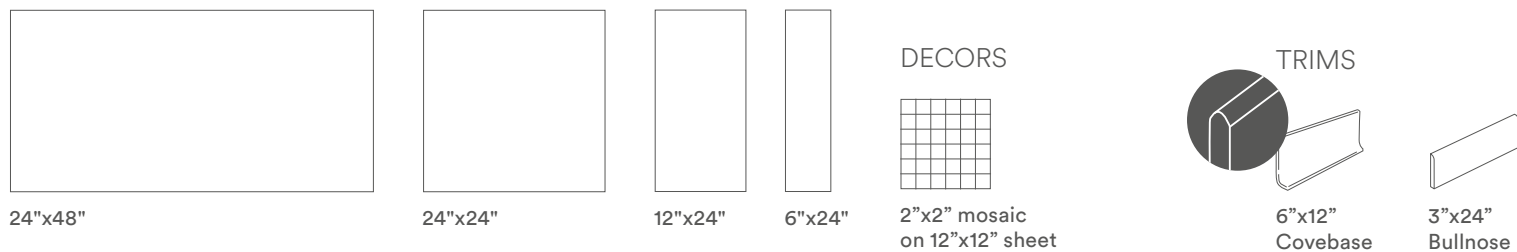

HOOK

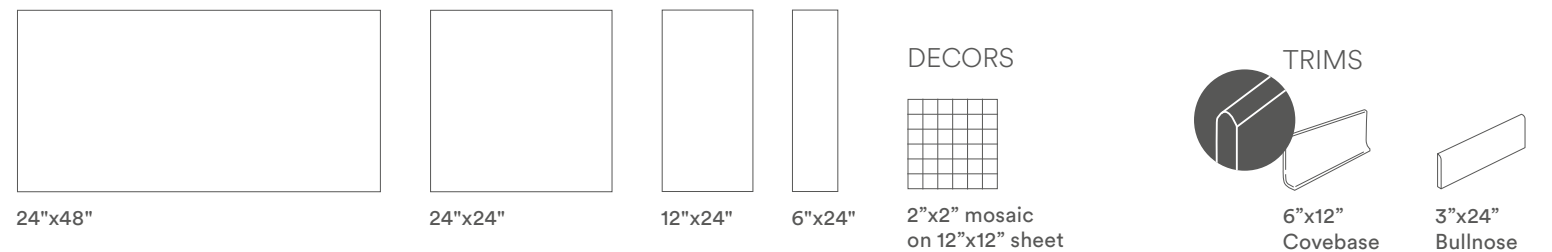

RANGE



● Matte, rectified, squared, one caliber

Available in all colors

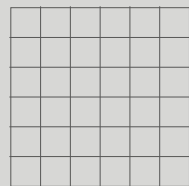

2"x2" mosaic on 12"x12" sheet

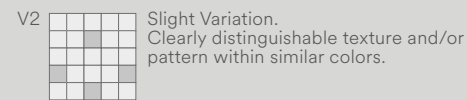

All sizes are nominal. For actual size information please refer to page 177.

PACKAGING

Size	Box		Pallet								
	Inches	Pcs	Surface (sqf)	Surface (sqm)	Weigth (lbs)	Weigth (kg)	Boxes	Surface (sqf)	Surface (sqm)	Weigth (lbs)	Weigth (kg)
24"x48"	24	2	15.51	144	~62.81	~28.4	35	542.85	50.43	~2200	~997
24"x24"	24	3	11.62	108	~47.62	~21.6	40	465	43.2	~1904.8	~864
12"x24"	12	7	13.56	126	~55.56	~25.2	40	542.51	50.4	~2222.4	~1008
6"x24"	6	12	11.62	108	~47.97	~21.6	40	465	43.2	~1904.8	~864
2"x 2" Mosaic	2	10 sheets	9.69	0.9	~39.68	~18	36	348.75	32.4	~1428.58	~648

We recommend you a 2/3 mm grout joint to simplify the laying and optimize the naturalness of the final result. In order to favour the ordinary maintenance procedures, it is recommended to carry out an acid wash of the surface after 48 hours from grout filling using an acid agent specific for porcelain stoneware tiles.

Caesar Ceramics USA reserves the right to change the products presented in this catalogue at any time.

Tones of samples are indicative

For information about installation and cleaning of Caesar products, please consult our general catalogue or the website www.caesarceramicsusa.com. Color reproductions may vary from actual products. Caesar reserves the right to modify the products illustrated in this catalogue for reasons of production or to improve quality. Samples are purely indicative. Packaging and weights may vary for production reasons. Contact our sales department when ordering. In case of running pattern installation, Caesar recommends a maximum 33% offset. Caesar warrants that our products meet or exceed the requirements of ANSI, specification ANSI A137.1: 2012, as shown in our Tile Performance Data sheets.

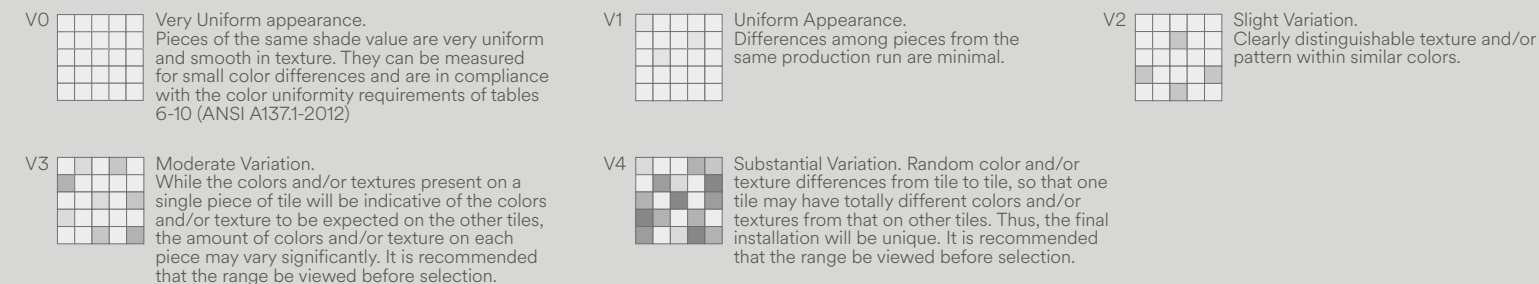

LINK TILE PERFORMANCE DATA

Color-body porcelain stoneware tiles are produced minimizing the color difference between the glaze and the body. Nevertheless, the design is visible only on the surface.



TECHNICAL FEATURE	METHOD	VALUE REQUIRED ANSI A 137.1	CAESAR AVERAGE VALUE
Facial dimension	ASTM C-499	± 0.25% or ± 0.03 in	In accordance to ANSI A 137.1
Wedging	ASTM C-502	± 0.25% or ± 0.03 in	
Warpage diagonal	ASTM C-485	± 0.4% or ± 0.07 in	
Warpage edge	ASTM C-485	± 0.4% or ± 0.05 in	
Thickness	ASTM C-499	RANGE: 0.040 inch max (1 mm)	In accordance to ANSI A 137.1
Water absorption	ASTM C-373	≤ 0.5%	Passed "impervious tiles" Class P1
Breaking strength	ASTM C-648	≥ 250 lbs (≥1113 N)	≥400 lbs
Freeze thaw	ASTM C-1026	No damages	In accordance
Chemical resistance	ASTM C-650	As reported	Unaffected
MOHS hardness			6
Dynamic Coefficient of Friction	ANSI A 326.3	Declare	WET DOCF ≥0.42
		Classified	Interior Wet

Average values referred to the last two years of production and related to the matte finish of the product. Values relate to the matte finish of the product and to tests carried out by certified external laboratories, whose results are available upon request. Be sure to use the same caliber tiles. Color reproductions may vary from actual products. * Due to the intrinsic nature of porcelain stoneware tiles, please note that the coefficient of friction may vary from one production lot to another. Caesar products can become slippery when wet. We recommend to always keep the surface dry.

NATURE

— THE NATIVE SOUL OF WOOD

COLOR-BODY PORCELAIN TILES
RECTIFIED - MATTE FINISH

BIRCH



MAPLE



PINE



CHESTNUT



SIZES

8"x40"



8"x40" CHEVRON



DECORS



8"x40"
stave



wood NATURE

Floor: Chevron Pine 8"x40"
Wall: Stave Pine 8"x40"



Floor: Chevron Pine 8"x40"
Wall: Stave Pine 8"x40"



Floor: Maple 8"x40"

wood NATURE



Wall: Stave Chestnut 8"x40"
Floor: Chestnut 8"x40"



Wall: Stave Chestnut 8"x40"
Floor: Birch 8"x40"

BIRCH

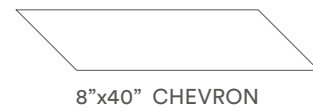
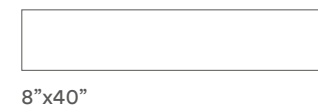

DECORS

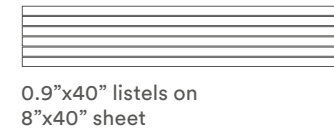

TRIMS

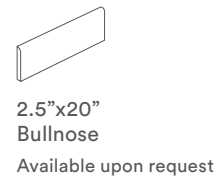

MAPLE

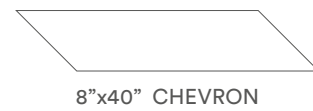
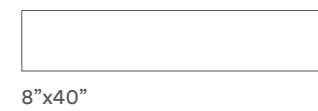

DECORS

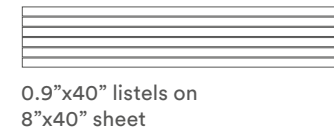

TRIMS

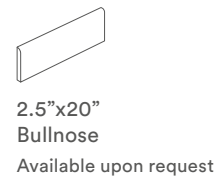

PINE

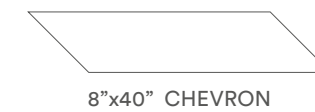

DECORS

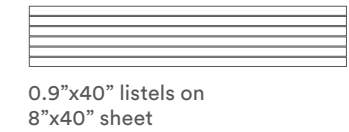

TRIMS



CHESTNUT

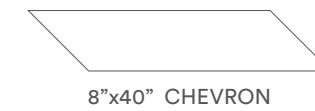
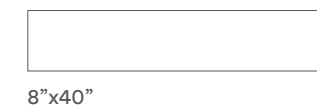

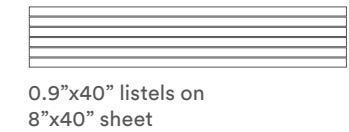

DECORS



TRIMS

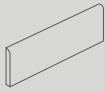

RANGE

			
	8"x40" 9 mm	8"x40" 9 mm	2.5"x20" Bullnose (Available upon request)
BIRCH	●	●	●
MAPLE	●	●	●
PINE	●	●	●
CHESTNUT	●	●	●

● Matte, rectified, squared, one caliber

Available in all colors



0.9"x40" listels on 8"x40" sheet

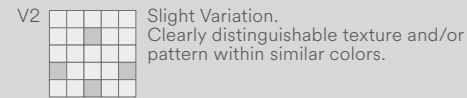

All sizes are nominal. For actual size information please refer to page 177.

PACKAGING





Size	Box		Pallet								
	Inches	Pcs	Surface (sqf)	Surface (sqm)	Weigth (lbs)	Weigth (kg)	Boxes	Surface (sqf)	Surface (sqm)	Weigth (lbs)	Weigth (kg)
8"x40"	8"x40"	6	12.92	1.2	~56.88	~25.8	36	465.00	43.20	~2,047.6	~928.8
8"x40" Chevron	8"x40"	6	10.33	0.96	~43.39	~19.68	30	310.00	28.80	~1,301.60	~590.4
Stave (0.9"x40" listels on 8"x40" sheet)	8"x40"	10 sheets	-	-	~17.64	~8	70	-	-	-	-

We recommend you a 2/3 mm grout joint to simplify the laying and optimize the naturalness of the final result. In order to favour the ordinary maintenance procedures, it is recommended to carry out an acid wash of the surface after 48 hours from grout filling using an acid agent specific for porcelain stoneware tiles.

Caesar Ceramics USA reserves the right to change the products presented in this catalogue at any time.

Tones of samples are indicative











For information about installation and cleaning of Caesar products, please consult our general catalogue or the website www.caesarceramicsusa.com. Color reproductions may vary from actual products. Caesar reserves the right to modify the products illustrated in this catalogue for reasons of production or to improve quality. Samples are purely indicative. Packaging and weights may vary for production reasons. Contact our sales department when ordering. In case of running pattern installation, Caesar recommends a maximum 33% offset. Caesar warrants that our products meet or exceed the requirements of ANSI, specification ANSI A137.1: 2012, as shown in our Tile Performance Data sheets.

V0  Very Uniform appearance. Pieces of the same shade value are very uniform and smooth in texture. They can be measured for small color differences and are in compliance with the color uniformity requirements of tables 6-10 (ANSI A137.1-2012)	V1  Uniform Appearance. Differences among pieces from the same production run are minimal.	V2  Slight Variation. Clearly distinguishable texture and/or pattern within similar colors.
V3  Moderate Variation. While the colors and/or textures present on a single piece of tile will be indicative of the colors and/or texture to be expected on the other tiles, the amount of colors and/or texture on each piece may vary significantly. It is recommended that the range be viewed before selection.	V4  Substantial Variation. Random color and/or texture differences from tile to tile, so that one tile may have totally different colors and/or textures from that on other tiles. Thus, the final installation will be unique. It is recommended that the range be viewed before selection.	

NATURE TILE PERFORMANCE DATA

Color-body porcelain stoneware tiles are produced minimizing the color difference between the glaze and the body. Nevertheless, the design is visible only on the surface.



TECHNICAL FEATURE	METHOD	VALUE REQUIRED ANSI A 137.1	CAESAR AVERAGE VALUE
 Facial dimension	ASTM C-499	± 0.25% or ± 0.03 in	
 Wedging	ASTM C-502	± 0.25% or ± 0.03 in	
 Warp diagonal	ASTM C-485	± 0.4% or ± 0.07 in	In accordance to ANSI A 137.1
 Warp edge	ASTM C-485	± 0.4% or ± 0.05 in	
 Thickness	ASTM C-499	RANGE: 0.040 inch max (1 mm)	In accordance to ANSI A 137.1
 Water absorption	ASTM C-373	≤ 0.5%	Passed "impervious tiles" Class P1
 Breaking strength	ASTM C-648	≥ 250 lbs (≥1113 N)	≥400 lbs
 Freeze thaw	ASTM C-1026	No damages	In accordance
 Chemical resistance	ASTM C-650	As reported	Unaffected
 MOHS hardness			6
 Dynamic Coefficient of Friction	ANSI A 326.3	Declare Classified	WET DOCF ≥0.42 Interior Wet

Average values referred to the last two years of production and related to the matte finish of the product. Values relate to the matte finish of the product and to tests carried out by certified external laboratories, whose results are available upon request. Be sure to use the same caliber tiles. Color reproductions may vary from actual products. * Due to the intrinsic nature of porcelain stoneware tiles, please note that the coefficient of friction may vary from one production lot to another. Caesar products can become slippery when wet. We recommend to always keep the surface dry.

ORIGIN

MOTION THROUGH STONE

COLOR-BODY PORCELAIN TILES
RECTIFIED - MATTE FINISH

ARCTIC



DESERT



CANYON



BOULDER



SIZES

24"x48"



24"x24"



12"x24"

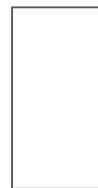

6"x24"



DECORS

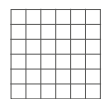

2"x2" mosaic
on 12"x12" sheet

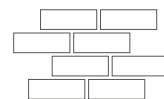

3"x8" brick mosaic
on 12"x16" sheet



stone ORIGIN

Wall: Run Sunray 12"x24"
Floor: Canyon 24"x48", 12"x24"



Wall: Arctic 12"x24", Canyon 12"x24", Mosaic Canyon 2"x2"
Floor: Arctic 24"x48", Mosaic Arctic 2"x2"



Floor: Desert 12"x24", 24"x24"

stone ORIGIN

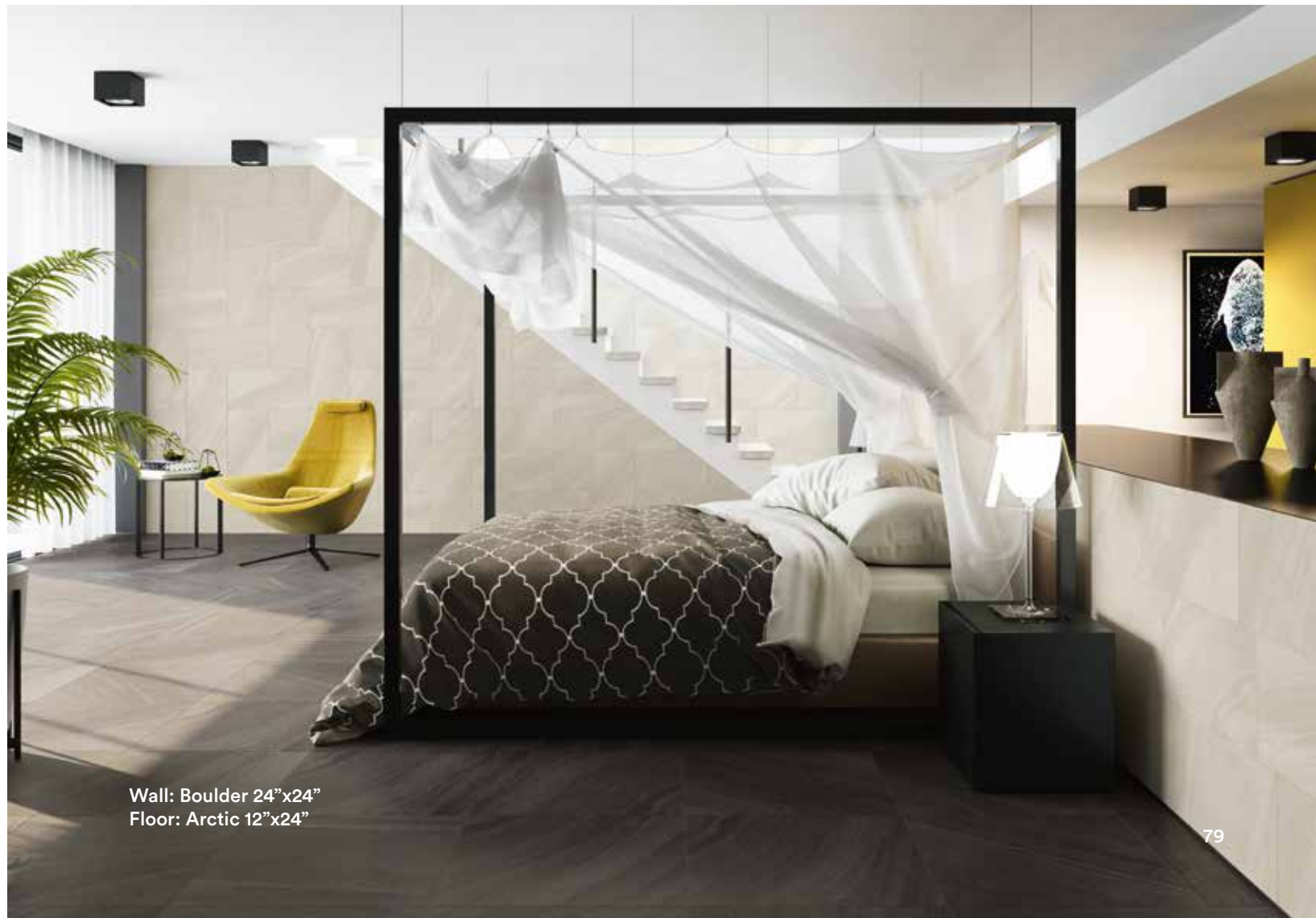

Wall: Boulder 24"x24"
Floor: Arctic 12"x24"

ARCTIC

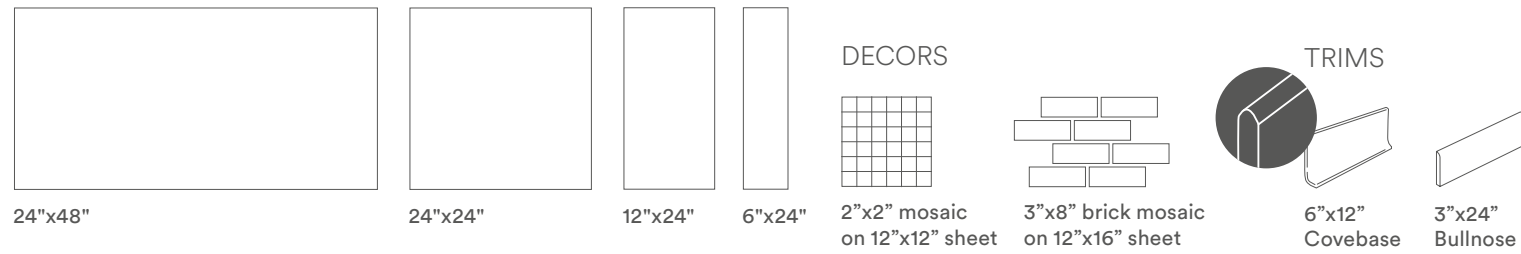

DESERT

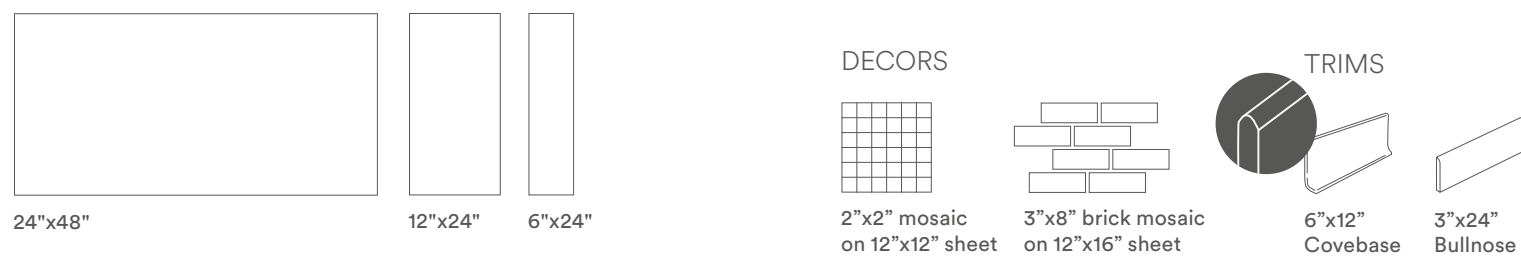

CANYON

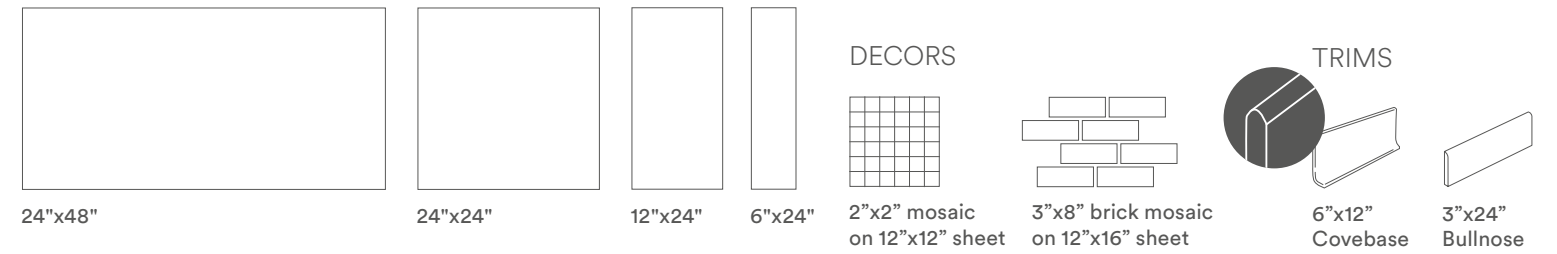

BOULDER

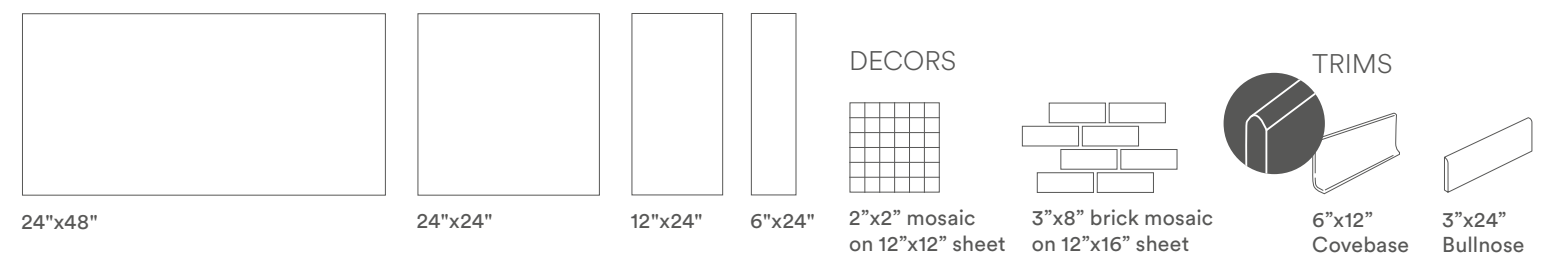

RANGE

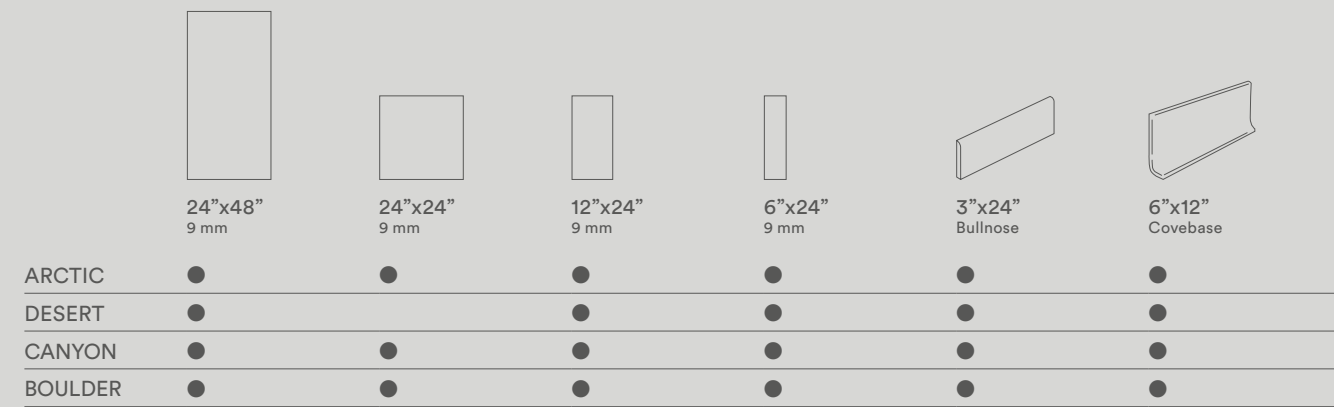

● Matte, rectified, squared, one caliber

Available in all colors

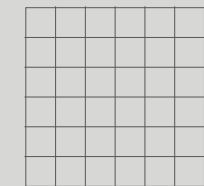

2"x2" mosaic on 12"x12" sheet

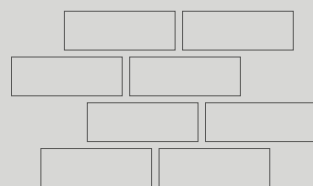

3"x8" mosaic on 12"x16" sheet

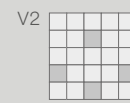

V2 Slight Variation. Clearly distinguishable texture and/or pattern within similar colors.

All sizes are nominal. For actual size information please refer to page 177.

PACKAGING

Size	Box		Pallet							
	Pcs	Surface (sqf)	Surface (sqm)	Weigth (lbs)	Weigth (kg)	Boxes	Surface (sqf)	Surface (sqm)	Weigth (lbs)	Weigth (kg)
24"x48"	2	15.51	144	~62.81	~28.4	35	542.85	50.43	~2200	~997
24"x24"	3	11.62	1.08	~47.62	~21.6	40	465	43.2	~1904.8	~864
12"x24"	7	13.56	1.26	~55.56	~25.2	40	542.51	50.4	~2222.4	~1008
6"x24"	12	11.62	1.08	~47.97	~21.6	40	465	43.2	~1904.8	~864
3"x8" Brick Mosaic	10 sheets	12.06	1.12	~49.38	~22.4	20	241.11	22.4	~987.66	~448
2"x2" Mosaic	10 sheets	9.69	0.9	~39.68	~18	36	348.75	32.4	~1428.6	~648

We recommend you a 2/3 mm grout joint to simplify the laying and optimize the naturalness of the final result. In order to favour the ordinary maintenance procedures, it is recommended to carry out an acid wash of the surface after 48 hours from grout filling using an acid agent specific for porcelain stoneware tiles.

Caesar Ceramics USA reserves the right to change the products presented in this catalogue at any time.

Tones of samples are indicative

For information about installation and cleaning of Caesar products, please consult our general catalogue or the website www.caesarceramicsusa.com. Color reproductions may vary from actual products. Caesar reserves the right to modify the products illustrated in this catalogue for reasons of production or to improve quality. Samples are purely indicative. Packaging and weights may vary for production reasons. Contact our sales department when ordering. In case of running pattern installation, Caesar recommends a maximum 33% offset. Caesar warrants that our products meet or exceed the requirements of ANSI, specification ANSI A137.1: 2012, as shown in our Tile Performance Data sheets.

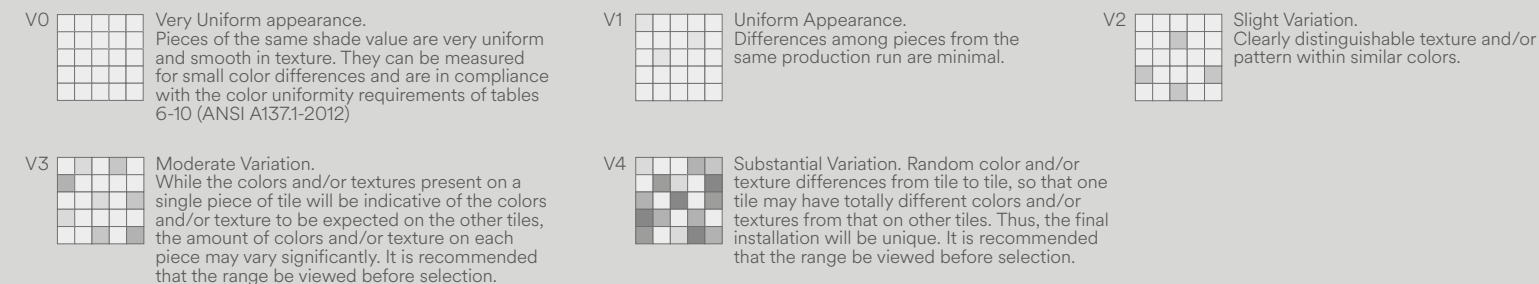

ORIGIN TILE PERFORMANCE DATA

Color-body porcelain stoneware tiles are produced minimizing the color difference between the glaze and the body. Nevertheless, the design is visible only on the surface.



TECHNICAL FEATURE	METHOD	VALUE REQUIRED ANSI A 137.1	CAESAR AVERAGE VALUE
Facial dimension	ASTM C-499	± 0.25% or ± 0.03 in	
Wedging	ASTM C-502	± 0.25% or ± 0.03 in	
Warp page diagonal	ASTM C-485	± 0.4% or ± 0.07 in	In accordance to ANSI A 137.1
Warp page edge	ASTM C-485	± 0.4% or ± 0.05 in	
Thickness	ASTM C-499	RANGE: 0.040 inch max (1 mm)	In accordance to ANSI A 137.1
Water absorption	ASTM C-373	≤ 0.5%	Passed "impervious tiles" Class P1
Breaking strength	ASTM C-648	≥ 250 lbs (≥1113 N)	≥400 lbs
Freeze thaw	ASTM C-1026	No damages	In accordance
Chemical resistance	ASTM C-650	As reported	Unaffected
MOHS hardness			6
Dynamic Coefficient of Friction	ANSI A 326.3	Declare Classified	WET DOCF ≥0.42 Interior Wet

Average values referred to the last two years of production and related to the matte finish of the product. Values relate to the matte finish of the product and to tests carried out by certified external laboratories, whose results are available upon request. Be sure to use the same caliber tiles. Color reproductions may vary from actual products. * Due to the intrinsic nature of porcelain stoneware tiles, please note that the coefficient of friction may vary from one production lot to another. Caesar products can become slippery when wet. We recommend to always keep the surface dry.

PATHWAY

— A JOURNEY INTO NATURAL BEAUTY

COLOR-BODY PORCELAIN TILES
RECTIFIED - MATTE FINISH

ICE SUN WIND ROCK



SIZES

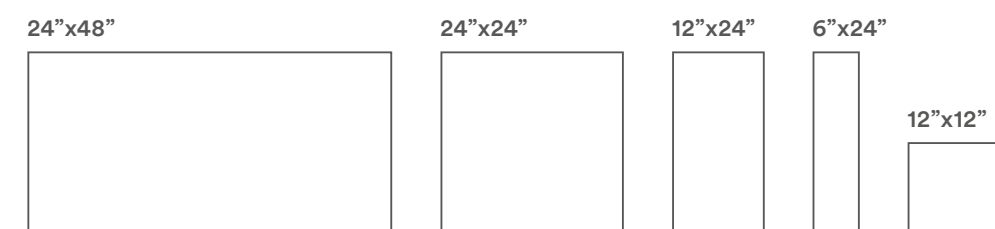

DECORS

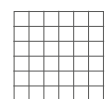

2"x2" mosaic
on 12"x12" sheet



2"x6.5" stretch mosaic
on 9.4"x12" sheet



stone PATHWAY

Floor: Sun 24"x24", 12"x24"
Wall: Sun, Ice, Rock 6"x24"



Floor: Ice 24"x48", Ice mosaic 12"x12"
 Wall: Ice 24"x48", Ice mosaic 12"x12"



Floor: Wind 48"x24", 24"x24", 12"x24", 12"x12"

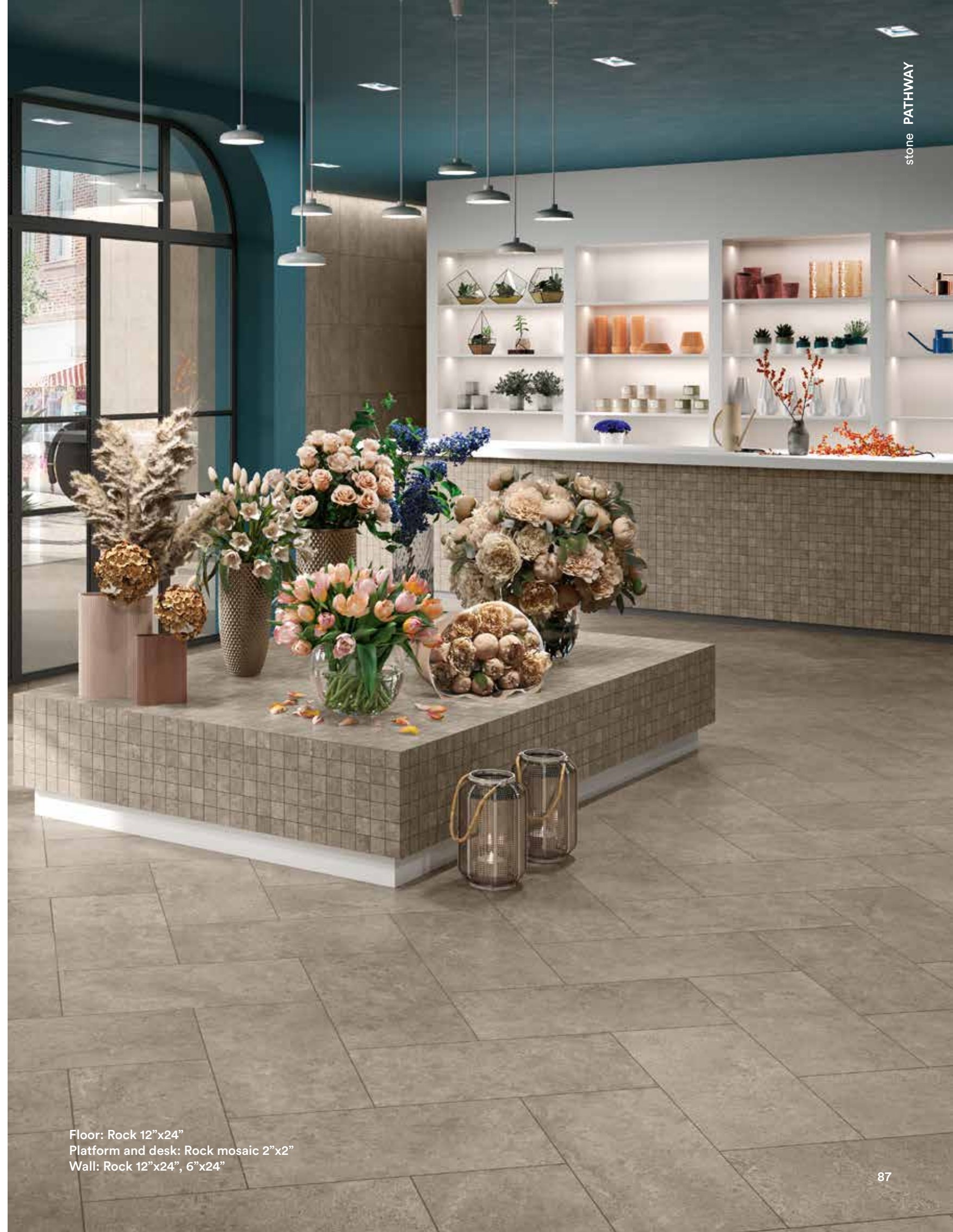

Floor: Rock 12"x24"
 Platform and desk: Rock mosaic 2"x2"
 Wall: Rock 12"x24", 6"x24"

ICE

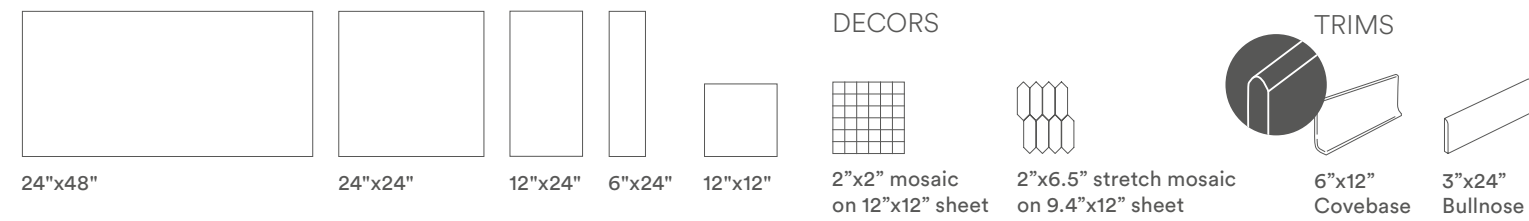

SUN

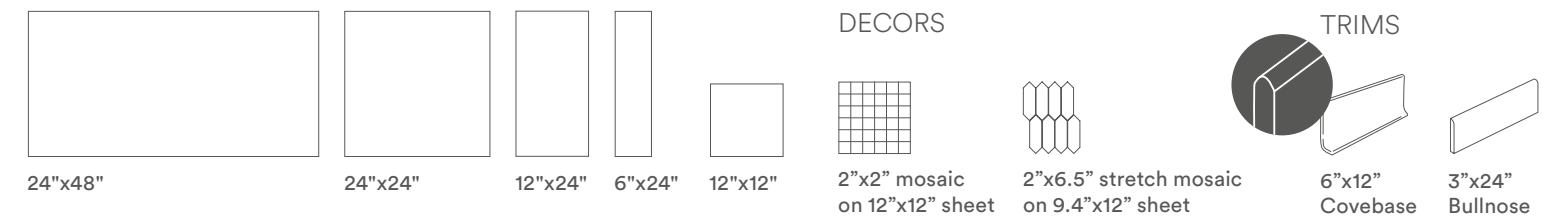

WIND

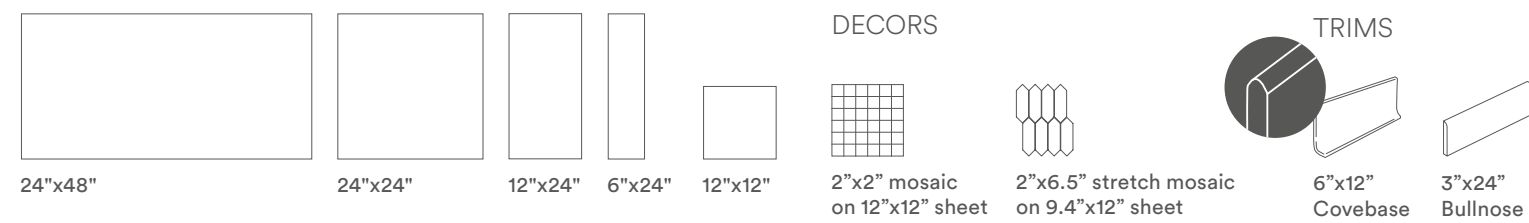

ROCK

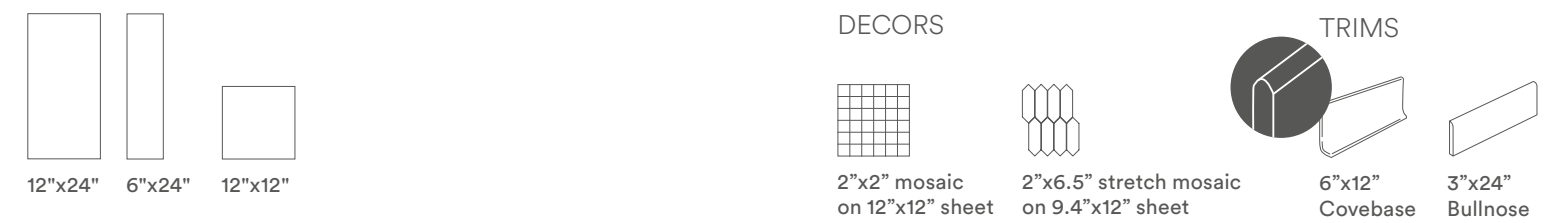

RANGE

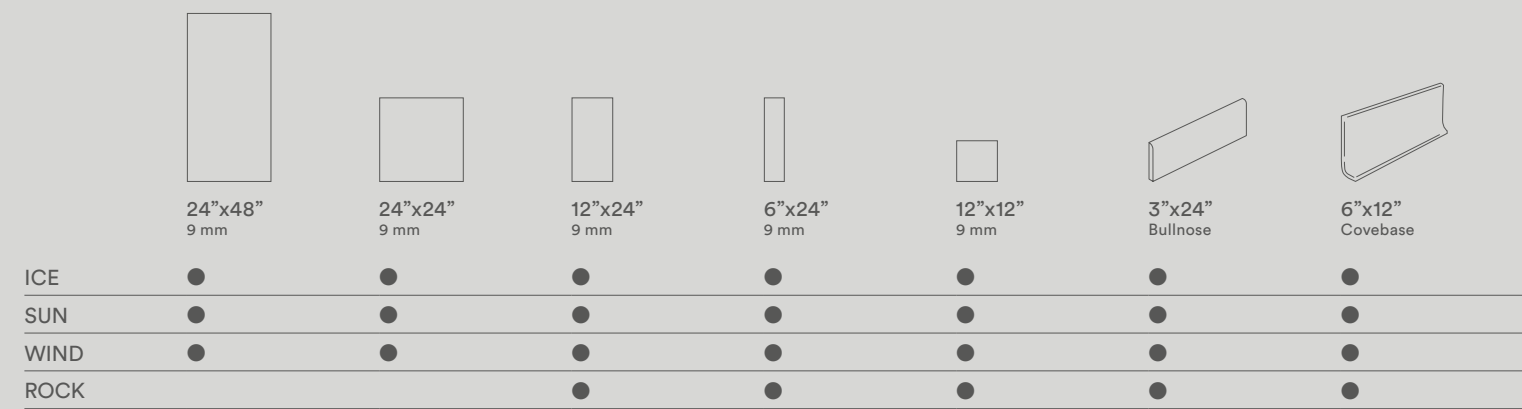

● Matte, rectified, squared, one caliber

Available in all colors

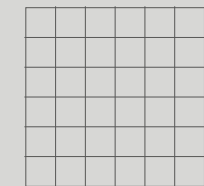

2"x2" mosaic on 12"x12" sheet

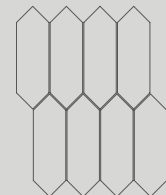

2"x6.5" stretch mosaic on 9.4"x12" sheet



V2 Slight Variation. Clearly distinguishable texture and/or pattern within similar colors.

All sizes are nominal. For actual size information please refer to page 177.

PACKAGING

Size	Box		Pallet								
	Inches	Pcs	Surface (sqf)	Surface (sqm)	Weight (lbs)	Weight (kg)	Boxes	Surface (sqf)	Surface (sqm)	Weight (lbs)	Weight (kg)
24"x 48"	24	2	15.51	1.44	~62.81	~28.4	35	542.85	50.43	~2200	~997
24"x24"	24	3	11.63	1.08	~47.62	~21.6	40	465.00	43.2	~1904.77	~864
12"x24"	12	7	13.56	1.26	~55.56	~25.2	40	542.51	50.4	~2222.4	~1008
2"x 2" Mosaic	2	10 sheets	9.69	0.9	~39.68	~18	36	348.75	32.4	~1428.6	~648

We recommend you a 2/3 mm grout joint to simplify the laying and optimize the naturalness of the final result. In order to favour the ordinary maintenance procedures, it is recommended to carry out an acid wash of the surface after 48 hours from grout filling using an acid agent specific for porcelain stoneware tiles.

Caesar Ceramics USA reserves the right to change the products presented in this catalogue at any time.

Tones of samples are indicative

For information about installation and cleaning of Caesar products, please consult our general catalogue or the website www.caesarceramicsusa.com. Color reproductions may vary from actual products. Caesar reserves the right to modify the products illustrated in this catalogue for reasons of production or to improve quality. Samples are purely indicative. Packaging and weights may vary for production reasons. Contact our sales department when ordering. In case of running pattern installation, Caesar recommends a maximum 33% offset. Caesar warrants that our products meet or exceed the requirements of ANSI, specification ANSI A137.1: 2012, as shown in our Tile Performance Data sheets.

V0 Very Uniform appearance. Pieces of the same shade value are very uniform and smooth in texture. They can be measured for small color differences and are in compliance with the color uniformity requirements of tables 6-10 (ANSI A137.1-2012)

V1 Uniform Appearance. Differences among pieces from the same production run are minimal.

V2 Slight Variation. Clearly distinguishable texture and/or pattern within similar colors.

V3 Moderate Variation. While the colors and/or textures present on a single piece of tile will be indicative of the colors and/or texture to be expected on the other tiles, the amount of colors and/or texture on each piece may vary significantly. It is recommended that the range be viewed before selection.

V4 Substantial Variation. Random color and/or texture differences from tile to tile, so that one tile may have totally different colors and/or textures from that on other tiles. Thus, the final installation will be unique. It is recommended that the range be viewed before selection.

PATHWAY TILE PERFORMANCE DATA

Color-body porcelain stoneware tiles are produced minimizing the color difference between the glaze and the body. Nevertheless, the design is visible only on the surface.



TECHNICAL FEATURE	METHOD	VALUE REQUIRED ANSI A 137.1	CAESAR AVERAGE VALUE
Facial dimension	ASTM C-499	± 0.25% or ± 0.03 in	
Wedging	ASTM C-502	± 0.25% or ± 0.03 in	
Warpage diagonal	ASTM C-485	± 0.4% or ± 0.07 in	In accordance to ANSI A 137.1
Warpage edge	ASTM C-485	± 0.4% or ± 0.05 in	
Thickness	ASTM C-499	RANGE: 0.040 inch max (1 mm)	In accordance to ANSI A 137.1
Water absorption	ASTM C-373	≤ 0.5%	Passed "impervious tiles" Class P1
Breaking strength	ASTM C-648	≥ 250 lbs (≥1113 N)	≥400 lbs
Freeze thaw	ASTM C-1026	No damages	In accordance
Chemical resistance	ASTM C-650	As reported	Unaffected
MOHS hardness			6
Dynamic Coefficient of Friction	ANSI A 326.3	Declare Classified	WET DOCF ≥0.42 Interior Wet

Average values referred to the last two years of production and related to the matte finish of the product. Values relate to the matte finish of the product and to tests carried out by certified external laboratories, whose results are available upon request. Be sure to use the same caliber tiles. Color reproductions may vary from actual products. * Due to the intrinsic nature of porcelain stoneware tiles, please note that the coefficient of friction may vary from one production lot to another. Caesar products can become slippery when wet. We recommend to always keep the surface dry.

PLACE

— AUTHENTIC SLATE DESIGNS

COLOR-BODY PORCELAIN TILES
RECTIFIED - MATTE FINISH

ALMOND



AMBER



RUST



SHALE



SIZES

24"x24"



12"x24"

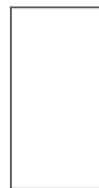

DECORS



2"x2" mosaic
on 12"x12" sheet



Floor: Shale 12"x24", 24"x24"



Outdoor: Almond 24"x24"



Floor: Amber 24"x24"



Floor: Rust 12"x24", 24"x24"

ALMOND

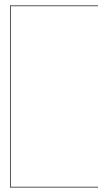

12"x24"

DECORS

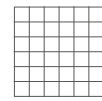

2"x2" mosaic
on 12"x12" sheet

TRIMS



6"x12"
Covebase

3"x24"
Bullnose

AMBER

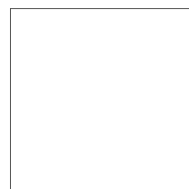

24"x24"



12"x24"

DECORS

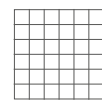

2"x2" mosaic
on 12"x12" sheet

TRIMS

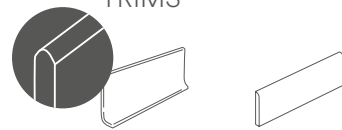

6"x12"
Covebase

3"x24"
Bullnose

SHALE



12"x24"

DECORS

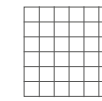

2"x2" mosaic
on 12"x12" sheet

TRIMS



6"x12"
Covebase

3"x24"
Bullnose

RUST



12"x24"

DECORS

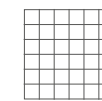

2"x2" mosaic
on 12"x12" sheet

TRIMS



6"x12"
Covebase

3"x24"
Bullnose

RANGE



	24"x24" 9 mm	12"x24" 9 mm	3"x24" Bullnose	6"x12" Covebase
ALMOND	●	●	●	●
AMBER	●	●	●	●
SHALE	●	●	●	●
RUST	●	●	●	●

● Matte, rectified, squared, one caliber

Available in all colors

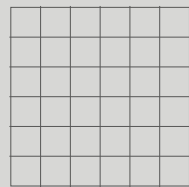

2"x2" mosaic
on 12"x12" sheet

V4  Substantial Variation. Random color and/or texture differences from tile to tile, so that one tile may have totally different colors and/or textures from that on other tiles. Thus, the final installation will be unique. It is recommended that the range be viewed before selection.

All sizes are nominal. For actual size information please refer to page 177.

PACKAGING





Size	Box		Pallet								
	Inches	Pcs	Surface (sqf)	Surface (sqm)	Weigth (lbs)	Weigth (kg)	Boxes	Surface (sqf)	Surface (sqm)	Weigth (lbs)	Weigth (kg)
24"x24"		3	11.63	1.08	~47.62	~21.6	40	465.00	43.2	~1904.77	~864
12"x24"		7	13.56	1.26	~55.56	~25.2	40	542.51	50.4	~2222.24	~1008
2"x 2" Mosaic		10 sheets	9.69	0.9	~39.68	~18	36	348.75	32.4	~1428.58	~648

We recommend you a 2/3 mm grout joint to simplify the laying and optimize the naturalness of the final result. In order to favour the ordinary maintenance procedures, it is recommended to carry out an acid wash of the surface after 48 hours from grout filling using an acid agent specific for porcelain stoneware tiles.

Caesar Ceramics USA reserves the right to change the products presented in this catalogue at any time.

Tones of samples are indicative



For information about installation and cleaning of Caesar products, please consult our general catalogue or the website www.caesarceramicsusa.com. Color reproductions may vary from actual products. Caesar reserves the right to modify the products illustrated in this catalogue for reasons of production or to improve quality. Samples are purely indicative. Packaging and weights may vary for production reasons. Contact our sales department when ordering. In case of running pattern installation, Caesar recommends a maximum 33% offset. Caesar warrants that our products meet or exceed the requirements of ANSI, specification ANSI A137.1: 2012, as shown in our Tile Performance Data sheets.

V0  Very Uniform appearance. Pieces of the same shade value are very uniform and smooth in texture. They can be measured for small color differences and are in compliance with the color uniformity requirements of tables 6-10 (ANSI A137.1-2012)	V1  Uniform Appearance. Differences among pieces from the same production run are minimal.	V2  Slight Variation. Clearly distinguishable texture and/or pattern within similar colors.
V3  Moderate Variation. While the colors and/or textures present on a single piece of tile will be indicative of the colors and/or texture to be expected on the other tiles, the amount of colors and/or texture on each piece may vary significantly. It is recommended that the range be viewed before selection.	V4  Substantial Variation. Random color and/or texture differences from tile to tile, so that one tile may have totally different colors and/or textures from that on other tiles. Thus, the final installation will be unique. It is recommended that the range be viewed before selection.	

PLACE TILE PERFORMANCE DATA

Color-body porcelain stoneware tiles are produced minimizing the color difference between the glaze and the body. Nevertheless, the design is visible only on the surface.



TECHNICAL FEATURE	METHOD	VALUE REQUIRED ANSI A 137.1	CAESAR AVERAGE VALUE
 Facial dimension	ASTM C-499	± 0.25% or ± 0.03 in	
 Wedging	ASTM C-502	± 0.25% or ± 0.03 in	
 Warp page diagonal	ASTM C-485	± 0.4% or ± 0.07 in	In accordance to ANSI A 137.1
 Warp page edge	ASTM C-485	± 0.4% or ± 0.05 in	
 Thickness	ASTM C-499	RANGE: 0.040 inch max (1 mm)	In accordance to ANSI A 137.1
 Water absorption	ASTM C-373	≤ 0.5%	Passed "impervious tiles" Class P1
 Breaking strength	ASTM C-648	≥ 250 lbs (≥1113 N)	≥400 lbs
 Freeze thaw	ASTM C-1026	No damages	In accordance
 Chemical resistance	ASTM C-650	As reported	Unaffected
 MOHS hardness			6
 Dynamic Coefficient of Friction	ANSI A 326.3	Declare Classified	WET DOCF ≥0.42 Interior Wet

Average values referred to the last two years of production and related to the matte finish of the product. Values relate to the matte finish of the product and to tests carried out by certified external laboratories, whose results are available upon request. Be sure to use the same caliber tiles. Color reproductions may vary from actual products. * Due to the intrinsic nature of porcelain stoneware tiles, please note that the coefficient of friction may vary from one production lot to another. Caesar products can become slippery when wet. We recommend to always keep the surface dry.

REVIVE

— THE WARMTH OF RECLAIMED WOOD

COLOR-BODY PORCELAIN TILES
NON-RECTIFIED - MATTE FINISH

VANILLA



SESAME



GINGER



COCOA



SIZES

8"x40"



Floor: Ginger 8"x40"



Floor: Vanilla 8"x40", Sesame 8"x40"



Floor: Sesame 8"x40", Brickmix Place Rust 12"x24"

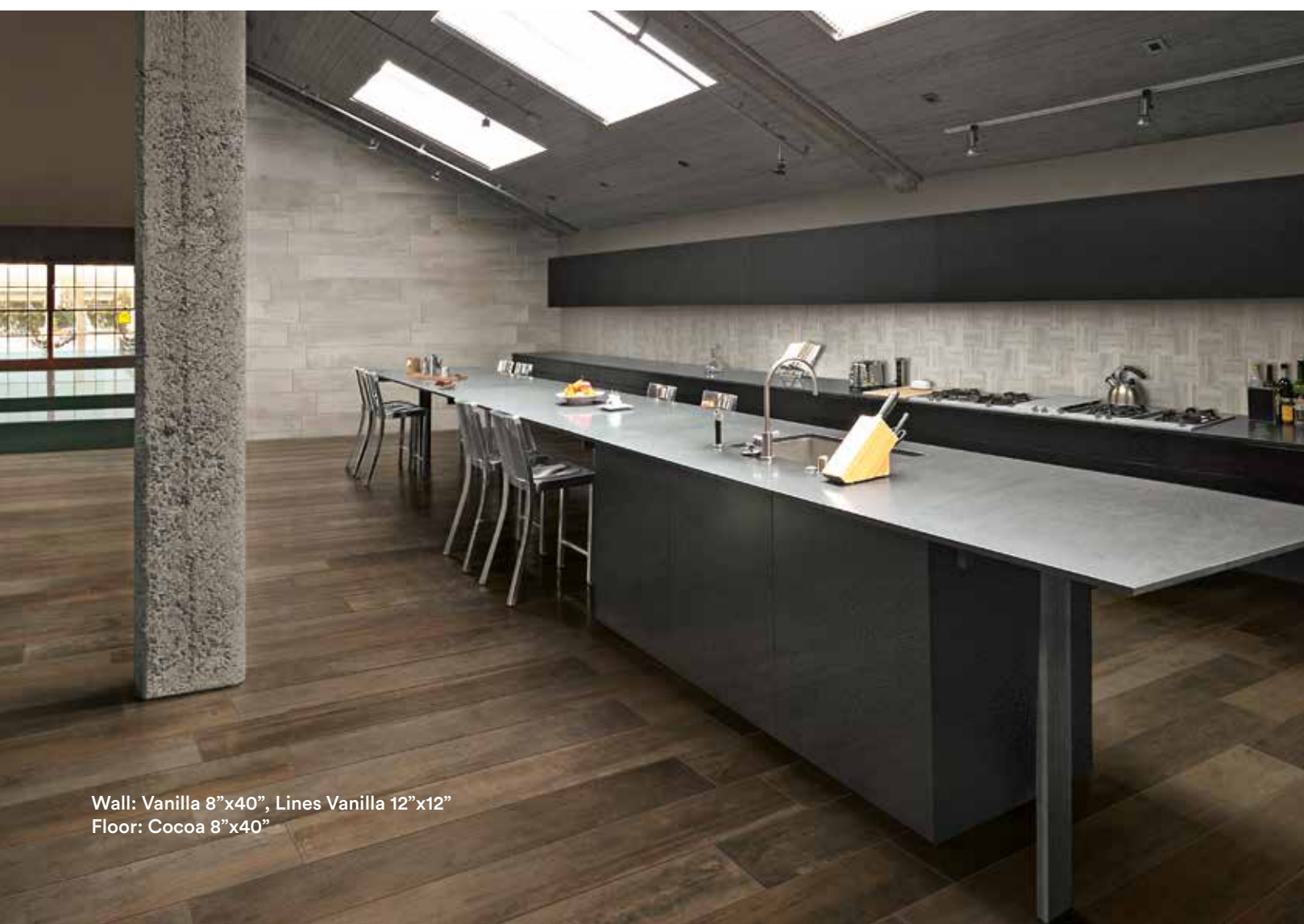

Wall: Vanilla 8"x40", Lines Vanilla 12"x12"
Floor: Cocoa 8"x40"

VANILLA



8"x40"

TRIMS



2.5"x20"
Bullnose
Available upon request

GINGER



8"x40"

TRIMS



2.5"x20"
Bullnose
Available upon request

SESAME



8"x40"

TRIMS



2.5"x20"
Bullnose
Available upon request

COCOA



8"x40"

TRIMS



2.5"x20"
Bullnose
Available upon request

RANGE

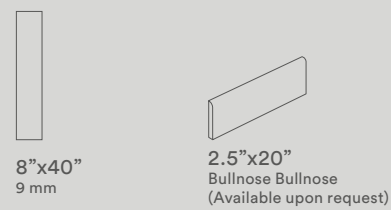

VANILLA	●	●
SESAME	●	●
GINGER	●	●
COCOA	●	●

● Matte, rectified, squared, one caliber

V4 Substantial Variation. Random color and/or texture differences from tile to tile, so that one tile may have totally different colors and/or textures from that on other tiles. Thus, the final installation will be unique. It is recommended that the range be viewed before selection.

All sizes are nominal. For actual size information please refer to page 177.

PACKAGING

Size	Box		Pallet							
	Inches	Pcs	Surface (sqf)	Surface (sqm)	Weigth (lbs)	Weigth (kg)	Boxes	Surface (sqf)	Surface (sqm)	Weigth (lbs)
8"x40"	6	12.92	1.2	~56.88	~25.8	36	465.00	43.20	~2,047.6	~928.8

We recommend you a 2/3 mm grout joint to simplify the laying and optimize the naturalness of the final result. In order to favour the ordinary maintenance procedures, it is recommended to carry out an acid wash of the surface after 48 hours from grout filling using an acid agent specific for porcelain stoneware tiles.

Caesar Ceramics USA reserves the right to change the products presented in this catalogue at any time.

Tones of samples are indicative

For information about installation and cleaning of Caesar products, please consult our general catalogue or the website www.caesarceramicsusa.com. Color reproductions may vary from actual products. Caesar reserves the right to modify the products illustrated in this catalogue for reasons of production or to improve quality. Samples are purely indicative. Packaging and weights may vary for production reasons. Contact our sales department when ordering. In case of running pattern installation, Caesar recommends a maximum 33% offset. Caesar warrants that our products meet or exceed the requirements of ANSI, specification ANSI A137.1: 2012, as shown in our Tile Performance Data sheets.

V0 Very Uniform appearance. Pieces of the same shade value are very uniform and smooth in texture. They can be measured for small color differences and are in compliance with the color uniformity requirements of tables 6-10 (ANSI A137.1-2012)	V1 Uniform Appearance. Differences among pieces from the same production run are minimal.	V2 Slight Variation. Clearly distinguishable texture and/or pattern within similar colors.
V3 Moderate Variation. While the colors and/or textures present on a single piece of tile will be indicative of the colors and/or texture to be expected on the other tiles, the amount of colors and/or texture on each piece may vary significantly. It is recommended that the range be viewed before selection.	V4 Substantial Variation. Random color and/or texture differences from tile to tile, so that one tile may have totally different colors and/or textures from that on other tiles. Thus, the final installation will be unique. It is recommended that the range be viewed before selection.	

REVIVE TILE PERFORMANCE DATA

Color-body porcelain stoneware tiles are produced minimizing the color difference between the glaze and the body. Nevertheless, the design is visible only on the surface.



TECHNICAL FEATURE	METHOD	VALUE REQUIRED ANSI A 137.1	CAESAR AVERAGE VALUE
Facial dimension	ASTM C-499	± 0.25% or ± 0.03 in	In accordance to ANSI A 137.1
Wedging	ASTM C-502	± 0.25% or ± 0.03 in	
Warpage diagonal	ASTM C-485	± 0.4% or ± 0.07 in	
Warpage edge	ASTM C-485	± 0.4% or ± 0.05 in	
Thickness	ASTM C-499	RANGE: 0.040 inch max (1 mm)	In accordance to ANSI A 137.1
Water absorption	ASTM C-373	≤ 0.5%	Passed "impervious tiles" Class P1
Breaking strength	ASTM C-648	≥ 250 lbs (≥1113 N)	≥400 lbs
Freeze thaw	ASTM C-1026	No damages	In accordance
Chemical resistance	ASTM C-650	As reported	Unaffected
MOHS hardness			6
Dynamic Coefficient of Friction	ANSI A 326.3	Declare	WET DOCF ≥0.42
		Classified	Interior Wet

Average values referred to the last two years of production and related to the matte finish of the product. Values relate to the matte finish of the product and to tests carried out by certified external laboratories, whose results are available upon request. Be sure to use the same caliber tiles. Color reproductions may vary from actual products. * Due to the intrinsic nature of porcelain stoneware tiles, please note that the coefficient of friction may vary from one production lot to another. Caesar products can become slippery when wet. We recommend to always keep the surface dry.

RUN

— THE ELEGANCE OF SOFT AND SUBTLE LINES

COLOR-BODY PORCELAIN TILES
RECTIFIED - MATTE FINISH

SALT

SUNRAY

CLAY

ROAD



SIZES

24"x48"



24"x24"



12"x24"



6"x24"



DECORS

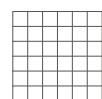

2"x2" mosaic
on 12"x12" sheet





Wall: Road 12"x24"



Wall: Salt 12"x24"
Floor: Salt 12"x24"

design RUN



Wall: Salt 6"x24"
Floor: Clay 24"x24"



Floor: Sunray 12"x24" - 24"x24"

SALT

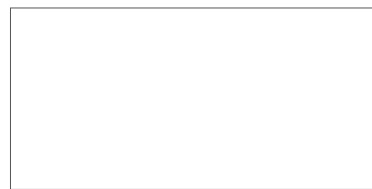

24"x48"



24"x24"



12"x24"



6"x24"

DECORS

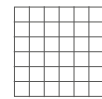

2"x2" mosaic
on 12"x12" sheet

TRIMS



6"x12"
Covebase



3"x24"
Bullnose

SUNRAY

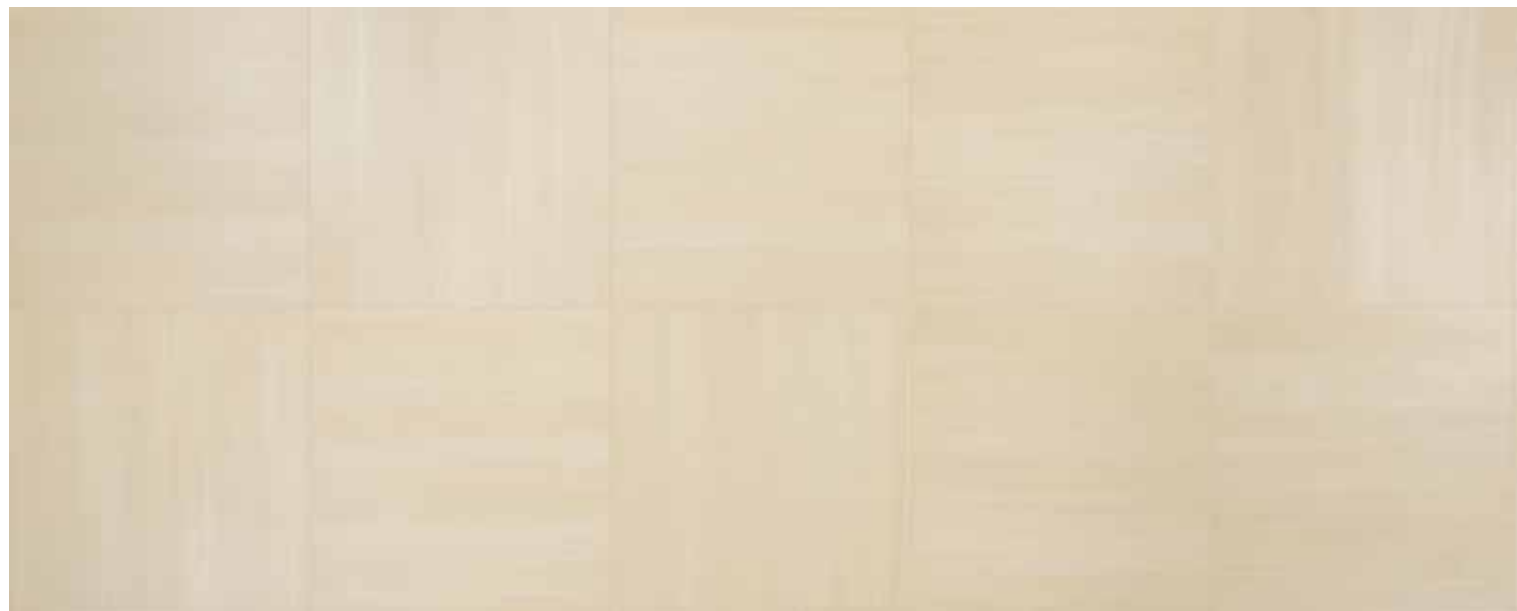

24"x48"



12"x24"



6"x24"

DECORS

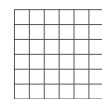

2"x2" mosaic
on 12"x12" sheet

TRIMS



6"x12"
Covebase



3"x24"
Bullnose

CLAY

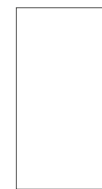

12"x24"



6"x24"

DECORS

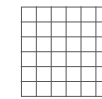

2"x2" mosaic
on 12"x12" sheet

TRIMS



6"x12"
Covebase

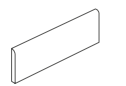

3"x24"
Bullnose

ROAD



12"x24"



6"x24"

DECORS

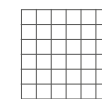

2"x2" mosaic
on 12"x12" sheet

TRIMS

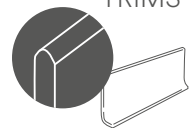

6"x12"
Covebase

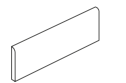

3"x24"
Bullnose

RANGE



24"x48"
9 mm



24"x24"
9 mm



12"x24"
9 mm



6"x24"
9 mm

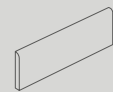

3"x24"
Bullnose

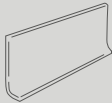

6"x12"
Covebase

CLAY			●	●	●	●
SALT	●	●	●	●	●	●
ROAD			●	●	●	●
SUNRAY	●		●	●	●	●

● Matte, rectified, squared, one caliber

Available in all colors

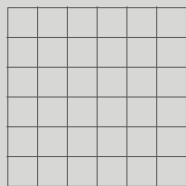

2"x2" mosaic
on 12"x12" sheet

V2



Slight Variation.
Clearly distinguishable texture and/or
pattern within similar colors.

All sizes are nominal. For actual size
information please refer to page 177.

PACKAGING

Size	Box		Pallet								
	Inches	Pcs	Surface (sqf)	Surface (sqm)	Weigth (lbs)	Weigth (kg)	Boxes	Surface (sqf)	Surface (sqm)	Weigth (lbs)	Weigth (kg)
24"x48"	24	2	15.51	144	~62.81	~28.4	35	542.85	50.43	~2200	~997
24"x24"	24	3	11.62	1.08	~47.62	~21.6	40	465	43.20	~1904.8	~864
12"x24"	12	7	13.56	1.26	~55.56	~25.2	40	542.51	50.40	~2222.4	~1008
6"x24"	6	12	11.62	1.08	~47.97	~21.6	40	465	43.2	~1904.8	~864
2"x 2" Mosaic	2	10 sheets	9.69	0.9	~39.68	~18	36	348.75	32.40	~1428.58	~648

We recommend you a 2/3 mm grout joint to simplify the laying and optimize the naturalness of the final result. In order to favour the ordinary maintenance procedures, it is recommended to carry out an acid wash of the surface after 48 hours from grout filling using an acid agent specific for porcelain stoneware tiles.

Caesar Ceramics USA reserves the right to change the products presented in this catalogue at any time.

Tones of samples are indicative

For information about installation and cleaning of Caesar products, please consult our general catalogue or the website www.caesarceramicsusa.com. Color reproductions may vary from actual products. Caesar reserves the right to modify the products illustrated in this catalogue for reasons of production or to improve quality. Samples are purely indicative. Packaging and weights may vary for production reasons. Contact our sales department when ordering. In case of running pattern installation, Caesar recommends a maximum 33% offset. Caesar warrants that our products meet or exceed the requirements of ANSI, specification ANSI A137.1: 2012, as shown in our Tile Performance Data sheets.

V0 Very Uniform appearance. Pieces of the same shade value are very uniform and smooth in texture. They can be measured for small color differences and are in compliance with the color uniformity requirements of tables 6-10 (ANSI A137.1-2012)

V1 Uniform Appearance. Differences among pieces from the same production run are minimal.

V2 Slight Variation. Clearly distinguishable texture and/or pattern within similar colors.

V3 Moderate Variation. While the colors and/or textures present on a single piece of tile will be indicative of the colors and/or texture to be expected on the other tiles, the amount of colors and/or texture on each piece may vary significantly. It is recommended that the range be viewed before selection.

V4 Substantial Variation. Random color and/or texture differences from tile to tile, so that one tile may have totally different colors and/or textures from that on other tiles. Thus, the final installation will be unique. It is recommended that the range be viewed before selection.

RUN TILE PERFORMANCE DATA

Color-body porcelain stoneware tiles are produced minimizing the color difference between the glaze and the body. Nevertheless, the design is visible only on the surface.



TECHNICAL FEATURE	METHOD	VALUE REQUIRED ANSI A 137.1	CAESAR AVERAGE VALUE
Facial dimension	ASTM C-499	± 0.25% or ± 0.03 in	In accordance to ANSI A 137.1
Wedging	ASTM C-502	± 0.25% or ± 0.03 in	
Warpage diagonal	ASTM C-485	± 0.4% or ± 0.07 in	
Warpage edge	ASTM C-485	± 0.4% or ± 0.05 in	
Thickness	ASTM C-499	RANGE: 0.040 inch max (1 mm)	In accordance to ANSI A 137.1
Water absorption	ASTM C-373	≤ 0.5%	Passed "impervious tiles" Class P1
Breaking strength	ASTM C-648	≥ 250 lbs (≥1113 N)	≥400 lbs
Freeze thaw	ASTM C-1026	No damages	In accordance
Chemical resistance	ASTM C-650	As reported	Unaffected
MOHS hardness			6
Dynamic Coefficient of Friction	ANSI A 326.3	Declare Classified	WET DOCF ≥0.42 Interior Wet

Average values referred to the last two years of production and related to the matte finish of the product. Values relate to the matte finish of the product and to tests carried out by certified external laboratories, whose results are available upon request. Be sure to use the same caliber tiles. Color reproductions may vary from actual products. * Due to the intrinsic nature of porcelain stoneware tiles, please note that the coefficient of friction may vary from one production lot to another. Caesar products can become slippery when wet. We recommend to always keep the surface dry.

SELECT

— STONES FOR A SUPERIOR DESIGN

COLOR-BODY PORCELAIN TILES
RECTIFIED - MATTE FINISH

SAVOY
WHITE



DOLOMITE
WHITE

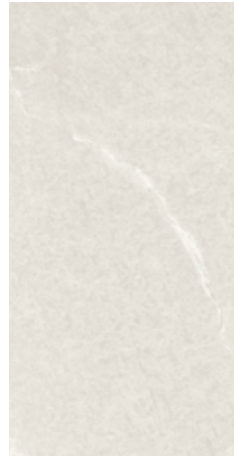

VANTA
WHITE

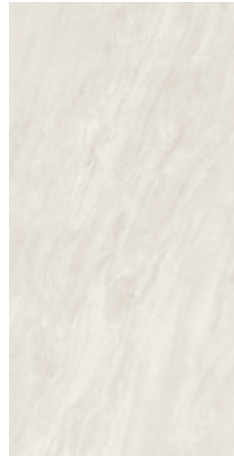

SAVOY
GRAY



DOLOMITE
GRAY

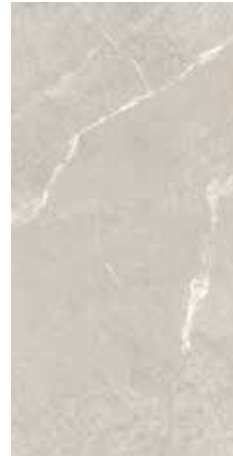

VANTA
GRAY



SIZES

24"x48"



24"x24"



12"x24"



6"x24"



DECORS

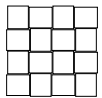

2.72"x3" basket
on 12"x12" sheet

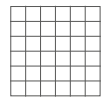

2"x2" mosaic
on 12"x12" sheet

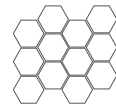

3"x3.5" hexagon
on 11"x12" sheet



Wall: Savoy Gray 24"x48"
Floor: Savoy White 24"x48" - Savoy White 12"x24"



Wall: Savoy Gray 24"x48"
 Floor: Savoy White 24"x48" - Savoy White 12"x24"
 Desk: Savoy Gray 2.72"x3" Basket



stone SELECT

Floor: Dolomite White 24"x48"
 Wall: Dolomite White 2.72"x3" Basket
 Desk: Dolomite White 24"x48"



Floor: Savoy Gray 24"x24" - Savoy White 24"x24"



Floor: Dolomite Gray 12"x24"
 Wall: Dolomite Gray 2.72"x3" Basket

SAVOY WHITE



DECORS

24"x48" 24"x24" 12"x24" 6"x24"

3"x3.5" hexagon on 11"x12" sheet 2"x2" mosaic on 12"x12" sheet 2.72"x3" basket on 12"x12" sheet

TRIMS

6"x12" Covebase 3"x24" Bullnose

DOLOMITE WHITE



DECORS

24"x48" 24"x24" 12"x24" 6"x24"

3"x3.5" hexagon on 11"x12" sheet 2"x2" mosaic on 12"x12" sheet 2.72"x3" basket on 12"x12" sheet

TRIMS

6"x12" Covebase 3"x24" Bullnose

SAVOY GRAY



DECORS

24"x48" 12"x24" 6"x24"

3"x3.5" hexagon on 11"x12" sheet 2"x2" mosaic on 12"x12" sheet 2.72"x3" basket on 12"x12" sheet

TRIMS

6"x12" Covebase 3"x24" Bullnose

DOLOMITE GRAY



DECORS

24"x48" 12"x24" 6"x24"





3"x3.5" hexagon on 11"x12" sheet 2"x2" mosaic on 12"x12" sheet 2.72"x3" basket on 12"x12" sheet



TRIMS



6"x12" Covebase 3"x24" Bullnose

VANTA WHITE





 24"x48"
 24"x24"
 12"x24"
 6"x24"



DECORS
 3"x3.5" hexagon on 11"x12" sheet
 2"x2" mosaic on 12"x12" sheet
 2.72"x3" basket on 12"x12" sheet



TRIMS
 6"x12" Covebase
 3"x24" Bullnose

VANTA GRAY



 24"x48"
 12"x24"
 6"x24"

DECORS
 3"x3.5" hexagon on 11"x12" sheet
 2"x2" mosaic on 12"x12" sheet
 2.72"x3" basket on 12"x12" sheet

TRIMS
 6"x12" Covebase
 3"x24" Bullnose







Wall: Vanta Gray 3"x3.5" Hexagon
 Floor: Vanta White 24"x48" - Vanta Gray 6"x24"

stone SELECT



Floor: Vanta Gray 24"x48" - Vanta White 2"x2" Mosaic
 Wall&Desk: Vanta White 2"x2" Mosaic

RANGE

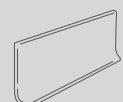
						
	24"x48" 9 mm	24"x24" 9 mm	12"x24" 9 mm	6"x24" 9 mm	3"x24" Bullnose	6"x12" Covebase
SAVOY WHITE	●	●	●	●	●	●
SAVOY GRAY	●	A	●	●	●	●
DOLOMITE WHITE	●	●	●	●	●	●
DOLOMITE GRAY	●	A	●	●	●	●
VANTA WHITE	●	●	●	●	●	●
VANTA GRAY	●	A	●	●	●	●

● Matte, rectified, squared, one caliber

A: available for >20.000 sf orders

Available in all colors

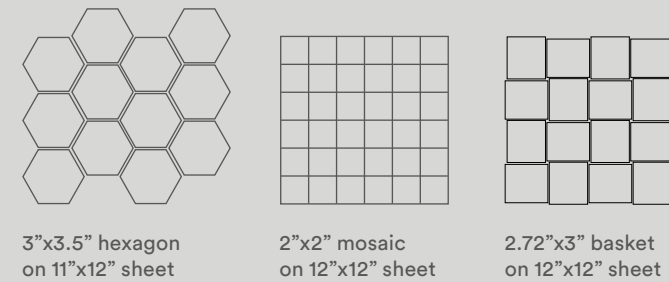

3"x3.5" hexagon on 11"x12" sheet

2"x2" mosaic on 12"x12" sheet

2.72"x3" basket on 12"x12" sheet

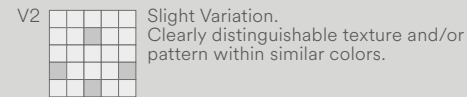

V2 Slight Variation. Clearly distinguishable texture and/or pattern within similar colors.

All sizes are nominal. For actual size information please refer to page 177.

PACKAGING





Size	Box				Pallet					
	Pcs	Surface (sqf)	Surface (sqm)	Weight (lbs)	Weight (kg)	Boxes	Surface (sqf)	Surface (sqm)	Weight (lbs)	Weight (kg)
24"x 48"	2	15.51	1.44	~62.81	~28.4	35	542.85	50.43	~2200	~997
24"x 24"	3	11.63	1.08	~47.62	~21.6	40	465.00	43.2	~1904.77	~864
12"x 24"	7	13.56	1.26	~55.56	~25.2	40	542.51	50.4	~2222.24	~1008
6"x 24"	12	11.63	1.08	~47.62	~21.6	40	465.00	43.2	~1904.77	~864
2"x 2" Mosaic	10 sheets	9.69	0.9	~39.68	~18	36	348.75	32.4	~1428.58	~648
3"x3.5" Hexagon Mosaic	10 sheets	8.93	0.83	~36.60	~16.6	36	321.48	29.88	~1317.6	~597.6
2.72"x3" Basket Mosaic	10 sheets	9.69	0.9	~39.68	~18	36	348.75	32.4	~1428.58	~648

We recommend you a 2/3 mm grout joint to simplify the laying and optimize the naturalness of the final result. In order to favour the ordinary maintenance procedures, it is recommended to carry out an acid wash of the surface after 48 hours from grout filling using an acid agent specific for porcelain stoneware tiles.

Caesar Ceramics USA reserves the right to change the products presented in this catalogue at any time.

Tones of samples are indicative











For information about installation and cleaning of Caesar products, please consult our general catalogue or the website www.caesarceramicsusa.com. Color reproductions may vary from actual products. Caesar reserves the right to modify the products illustrated in this catalogue for reasons of production or to improve quality. Samples are purely indicative. Packaging and weights may vary for production reasons. Contact our sales department when ordering. In case of running pattern installation, Caesar recommends a maximum 33% offset. Caesar warrants that our products meet or exceed the requirements of ANSI, specification ANSI A137.1: 2012, as shown in our Tile Performance Data sheets.

V0 	Very Uniform appearance. Pieces of the same shade value are very uniform and smooth in texture. They can be measured for small color differences and are in compliance with the color uniformity requirements of tables 6-10 (ANSI A137.1-2012)	V1 	Uniform Appearance. Differences among pieces from the same production run are minimal.	V2 	Slight Variation. Clearly distinguishable texture and/or pattern within similar colors.
V3 	Moderate Variation. While the colors and/or textures present on a single piece of tile will be indicative of the colors and/or texture to be expected on the other tiles, the amount of colors and/or texture on each piece may vary significantly. It is recommended that the range be viewed before selection.	V4 	Substantial Variation. Random color and/or texture differences from tile to tile, so that one tile may have totally different colors and/or textures from that on other tiles. Thus, the final installation will be unique. It is recommended that the range be viewed before selection.		

SELECT TILE PERFORMANCE DATA

Color-body porcelain stoneware tiles are produced minimizing the color difference between the glaze and the body. Nevertheless, the design is visible only on the surface.



TECHNICAL FEATURE	METHOD	VALUE REQUIRED ANSI A 137.1	CAESAR AVERAGE VALUE
 Facial dimension	ASTM C-499	± 0.25% or ± 0.03 in	
 Wedging	ASTM C-502	± 0.25% or ± 0.03 in	
 Warpage diagonal	ASTM C-485	± 0.4% or ± 0.07 in	
 Warpage edge	ASTM C-485	± 0.4% or ± 0.05 in	
 Thickness	ASTM C-499	RANGE: 0.040 inch max (1 mm)	In accordance to ANSI A 137.1
 Water absorption	ASTM C-373	≤ 0.5%	Passed "impervious tiles" Class P1
 Breaking strength	ASTM C-648	≥ 250 lbs (≥1113 N)	≥400 lbs
 Freeze thaw	ASTM C-1026	No damages	In accordance
 Chemical resistance	ASTM C-650	As reported	Unaffected
 MOHS hardness			6
 Dynamic Coefficient of Friction	ANSI A 326.3	Declare Classified	WET DOCF ≥0.42 Interior Wet

Average values referred to the last two years of production and related to the matte finish of the product. Values relate to the matte finish of the product and to tests carried out by certified external laboratories, whose results are available upon request. Be sure to use the same caliber tiles. Color reproductions may vary from actual products. * Due to the intrinsic nature of porcelain stoneware tiles, please note that the coefficient of friction may vary from one production lot to another. Caesar products can become slippery when wet. We recommend to always keep the surface dry.

STONEWAYS

— FLOWING ELEGANCE

COLOR-BODY PORCELAIN TILES
RECTIFIED - MATTE FINISH

SKY



FLIGHT



NIGHT



VELVET



SIZES

12"x24"



6"x24"



DECORS

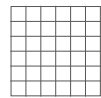

2"x2" mosaic
on 12"x12" sheet



1.3"x3.8" herringbone
on 12"x14.5" sheet



Floor: Stoneways Velvet 12"x24"
Wall: Stoneways Velvet 6"x24"



SKY

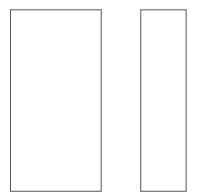

12"x24" 6"x24"

DECORS

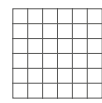

2"x2" mosaic on 12"x12" sheet



1.3"x3.8" herringbone on 12"x14.5" sheet

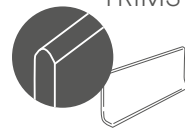

TRIMS

6"x12" Covebase



3"x24" Bullnose

NIGHT

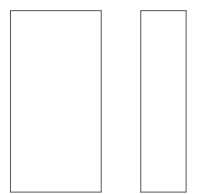

12"x24" 6"x24"

DECORS

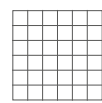

2"x2" mosaic on 12"x12" sheet



1.3"x3.8" herringbone on 12"x14.5" sheet

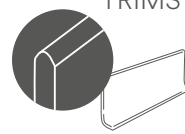

TRIMS

6"x12" Covebase



3"x24" Bullnose

FLIGHT

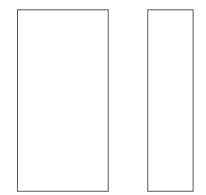

12"x24" 6"x24"

DECORS

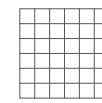

2"x2" mosaic on 12"x12" sheet



1.3"x3.8" herringbone on 12"x14.5" sheet

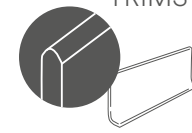

TRIMS

6"x12" Covebase



3"x24" Bullnose

VELVET

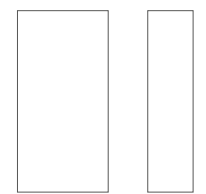

12"x24" 6"x24"

DECORS

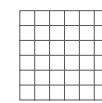

2"x2" mosaic on 12"x12" sheet



1.3"x3.8" herringbone on 12"x14.5" sheet

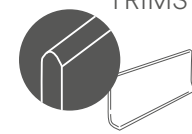

TRIMS

6"x12" Covebase



3"x24" Bullnose

RANGE

	12"x24" 9 mm	6"x24" 9 mm	3"x24" Bullnose	6"x12" Covebase
SKY	●	●	●	●
FLIGHT	●	●	●	●
NIGHT	●	●	●	●
VELVET	●	●	●	●

● Matte, rectified, squared, one caliber

Available in all colors

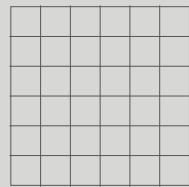

2"x2" mosaic
on 12"x12" sheet

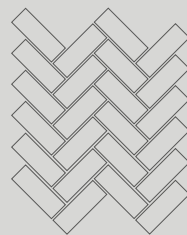

1.3"x3.8" herringbone
on 12"x14.5" sheet

V2



Slight Variation.
Clearly distinguishable texture and/or
pattern within similar colors.

All sizes are nominal. For actual size
information please refer to page 177.

PACKAGING

Size	Box		Pallet								
	Inches	Pcs	Surface (sqf)	Surface (sqm)	Weight (lbs)	Weight (kg)	Boxes	Surface (sqf)	Surface (sqm)	Weight (lbs)	Weight (kg)
12"x24"		7	13.56	1.26	~55.56	~25.2	40	542.51	50.4	~2222.2	~1008
6"x24"		12	11.62	1.08	~47.97	~21.6	40	465	43.2	~1904.8	~864
2"x2" Mosaic		10 sheets	9.69	0.9	~39.68	~18	36	348.75	32.4	~1428.6	~648
1.3"x3.8" Herringbone		7 sheets	6.46	0.6	~26.45	~12	36	232.56	21.6	~952.20	~432

We recommend you a 2/3 mm grout joint to simplify the laying and optimize the naturalness of the final result. In order to favour the ordinary maintenance procedures, it is recommended to carry out an acid wash of the surface after 48 hours from grout filling using an acid agent specific for porcelain stoneware tiles.

Caesar Ceramics USA reserves the right to change the products presented in this catalogue at any time.

Tones of samples are indicative

For information about installation and cleaning of Caesar products, please consult our general catalogue or the website www.caesarceramicsusa.com. Color reproductions may vary from actual products. Caesar reserves the right to modify the products illustrated in this catalogue for reasons of production or to improve quality. Samples are purely indicative. Packaging and weights may vary for production reasons. Contact our sales department when ordering. In case of running pattern installation, Caesar recommends a maximum 33% offset. Caesar warrants that our products meet or exceed the requirements of ANSI, specification ANSI A137.1: 2012, as shown in our Tile Performance Data sheets.

V0		Very Uniform appearance. Pieces of the same shade value are very uniform and smooth in texture. They can be measured for small color differences and are in compliance with the color uniformity requirements of tables 6-10 (ANSI A137.1-2012)
V1		Uniform Appearance. Differences among pieces from the same production run are minimal.
V2		Slight Variation. Clearly distinguishable texture and/or pattern within similar colors.
V3		Moderate Variation. While the colors and/or textures present on a single piece of tile will be indicative of the colors and/or texture to be expected on the other tiles, the amount of colors and/or texture on each piece may vary significantly. It is recommended that the range be viewed before selection.
V4		Substantial Variation. Random color and/or texture differences from tile to tile, so that one tile may have totally different colors and/or textures from that on other tiles. Thus, the final installation will be unique. It is recommended that the range be viewed before selection.

STONEWAYS TILE PERFORMANCE DATA

Color-body porcelain stoneware tiles are produced minimizing the color difference between the glaze and the body. Nevertheless, the design is visible only on the surface.



TECHNICAL FEATURE	METHOD	VALUE REQUIRED ANSI A 137.1	CAESAR AVERAGE VALUE
Facial dimension	ASTM C-499	± 0.25% or ± 0.03 in	
Wedging	ASTM C-502	± 0.25% or ± 0.03 in	
Warpage diagonal	ASTM C-485	± 0.4% or ± 0.07 in	In accordance to ANSI A 137.1
Warpage edge	ASTM C-485	± 0.4% or ± 0.05 in	
Thickness	ASTM C-499	RANGE: 0.040 inch max (1 mm)	In accordance to ANSI A 137.1
Water absorption	ASTM C-373	≤ 0.5%	Passed "impervious tiles" Class P1
Breaking strength	ASTM C-648	≥ 250 lbs (≥1113 N)	≥400 lbs
Freeze thaw	ASTM C-1026	No damages	In accordance
Chemical resistance	ASTM C-650	As reported	Unaffected
MOHS hardness			6
Dynamic Coefficient of Friction	ANSI A 326.3	Declare Classified	WET DOCF ≥0.42 Interior Wet

Average values referred to the last two years of production and related to the matte finish of the product. Values relate to the matte finish of the product and to tests carried out by certified external laboratories, whose results are available upon request. Be sure to use the same caliber tiles. Color reproductions may vary from actual products. * Due to the intrinsic nature of porcelain stoneware tiles, please note that the coefficient of friction may vary from one production lot to another. Caesar products can become slippery when wet. We recommend to always keep the surface dry.

STYLE

— SMOOTH LINES, MODERN ATTITUDE

COLOR-BODY PORCELAIN TILES
RECTIFIED - MATTE FINISH

PURE

LIVELY

ELEGANT

RICH



SIZES

12"x24"



6"x24"



DECORS



2"x2" mosaic
on 12"x12" sheet



design STYLE

Floor: Elegant 8"x40"



Floor: Pure 12"x24"
Wall: Lively 6"x24"
Shower Floor: Pure mosaic 2"x2"
Shower Wall: Pure 12"x24", Lively 12"x24", Pure mosaic 2"x2"



Floor: Lively 12"x24"
Wall: Join Dusk Spice 48"x109"
Counter: Rich 8"x40"

Design STYLE



Floor: Rich 8"x40"
Wall: Pure mosaic 2"x2"

PURE

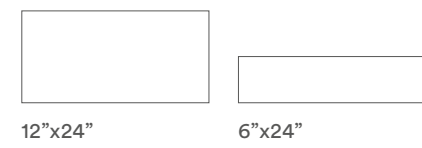

DECORS

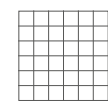

2"x2" mosaic
on 12"x12" sheet
randomly mixed

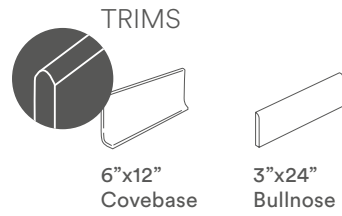

TRIMS

6"x12" Covebase
3"x24" Bullnose

ELEGANT

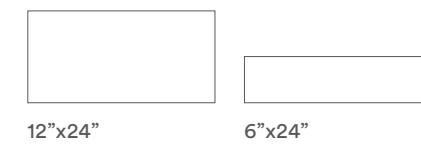
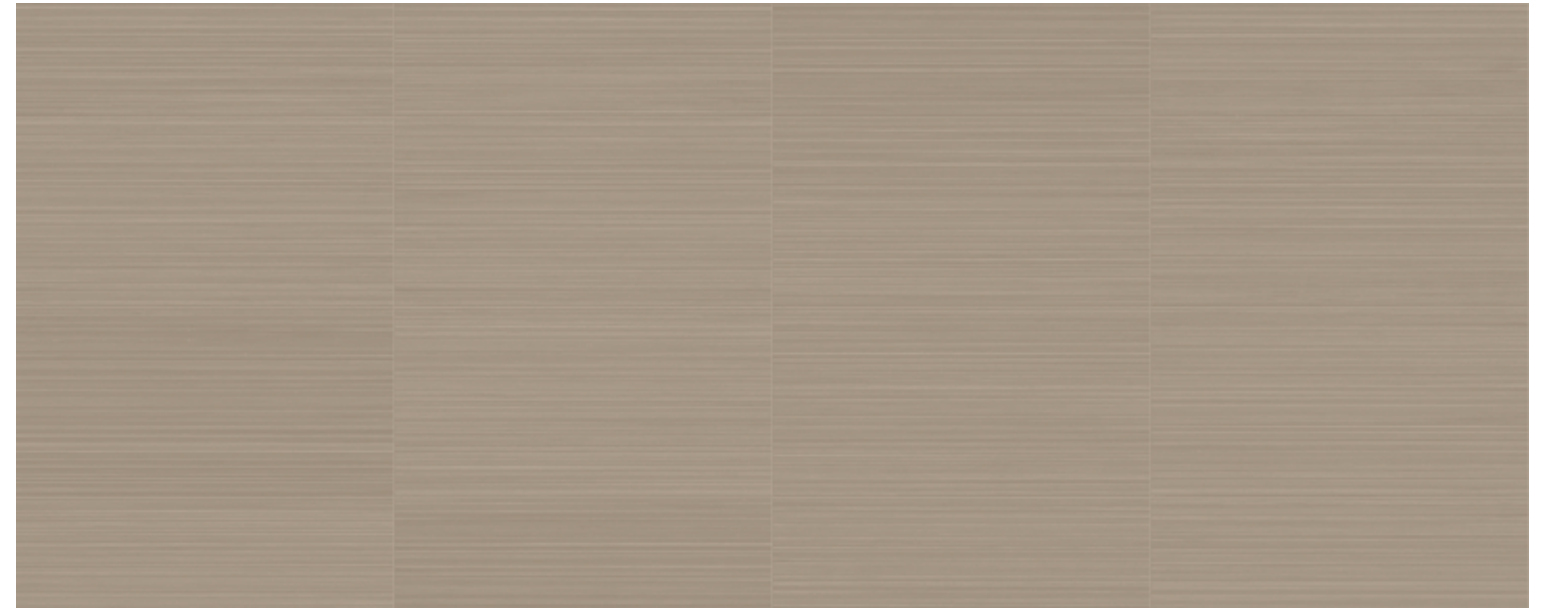

DECORS

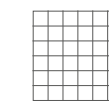

2"x2" mosaic
on 12"x12" sheet
randomly mixed

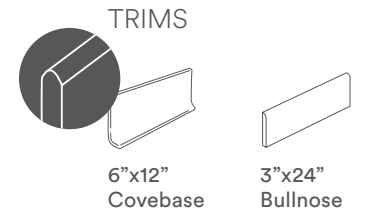

TRIMS

6"x12" Covebase
3"x24" Bullnose

LIVELY

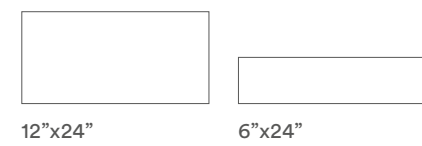

DECORS

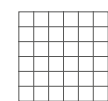

2"x2" mosaic
on 12"x12" sheet
randomly mixed

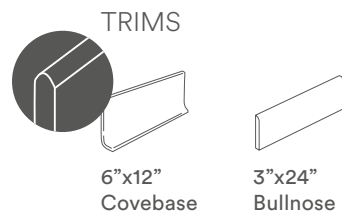

TRIMS

6"x12" Covebase
3"x24" Bullnose

RICH

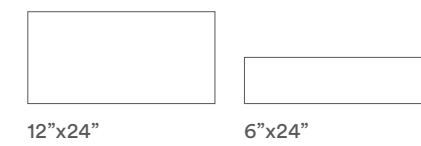

DECORS



2"x2" mosaic
on 12"x12" sheet
randomly mixed

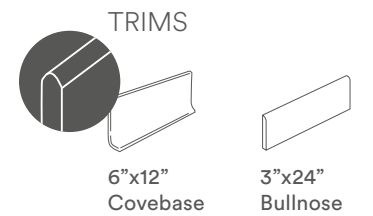

TRIMS

6"x12" Covebase
3"x24" Bullnose

RANGE

	12"x24" 9 mm	6"x24" 9 mm	3"x24" Bullnose	6"x12" Covebase
PURE	●	●	●	●
LIVELY	●	●	●	●
ELEGANT	●	●	●	●
RICH	●	●	●	●

● Matte, rectified, squared, one caliber

Available in all colors

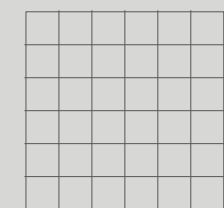

2"x2" mosaic
on 12"x12" sheet
randomly mixed

PACKAGING





Size	Box				Pallet					
	Pcs	Surface (sqf)	Surface (sqm)	Weight (lbs)	Weight (kg)	Boxes	Surface (sqf)	Surface (sqm)	Weight (lbs)	Weight (kg)
8"x40"	6	12.92	1.2	~56.88	~25.8	36	465	43.20	~2,047.6	~928.8
12"x24"	7	13.56	1.26	~55.56	~25.2	40	542.51	50.40	~2222.2	~1008
6"x24"	12	11.62	1.08	~47.97	~21.6	40	465	43.20	~1904.8	~864
2"x2" Mosaic	10 sheets	9.69	0.9	~39.68	~18	36	348.75	32.40	~1428.6	~648

We recommend you a 2/3 mm grout joint to simplify the laying and optimize the naturalness of the final result. In order to favour the ordinary maintenance procedures, it is recommended to carry out an acid wash of the surface after 48 hours from grout filling using an acid agent specific for porcelain stoneware tiles.

Caesar Ceramics USA reserves the right to change the products presented in this catalogue at any time.

Tones of samples are indicative

For information about installation and cleaning of Caesar products, please consult our general catalogue or the website www.caesarceramicsusa.com. Color reproductions may vary from actual products. Caesar reserves the right to modify the products illustrated in this catalogue for reasons of production or to improve quality. Samples are purely indicative. Packaging and weights may vary for production reasons. Contact our sales department when ordering. In case of running pattern installation, Caesar recommends a maximum 33% offset. Caesar warrants that our products meet or exceed the requirements of ANSI, specification ANSI A137.1: 2012, as shown in our Tile Performance Data sheets.

V0  Very Uniform appearance. Pieces of the same shade value are very uniform and smooth in texture. They can be measured for small color differences and are in compliance with the color uniformity requirements of tables 6-10 (ANSI A137.1-2012)	V1  Uniform Appearance. Differences among pieces from the same production run are minimal.	V2  Slight Variation. Clearly distinguishable texture and/or pattern within similar colors.
V3  Moderate Variation. While the colors and/or textures present on a single piece of tile will be indicative of the colors and/or texture to be expected on the other tiles, the amount of colors and/or texture on each piece may vary significantly. It is recommended that the range be viewed before selection.	V4  Substantial Variation. Random color and/or texture differences from tile to tile, so that one tile may have totally different colors and/or textures from that on other tiles. Thus, the final installation will be unique. It is recommended that the range be viewed before selection.	

All sizes are nominal. For actual size information please refer to page 177.

STYLE TILE PERFORMANCE DATA

Color-body porcelain stoneware tiles are produced minimizing the color difference between the glaze and the body. Nevertheless, the design is visible only on the surface.



TECHNICAL FEATURE	METHOD	VALUE REQUIRED ANSI A 137.1	CAESAR AVERAGE VALUE
 Facial dimension	ASTM C-499	± 0.25% or ± 0.03 in	
 Wedging	ASTM C-502	± 0.25% or ± 0.03 in	
 Warpage diagonal	ASTM C-485	± 0.4% or ± 0.07 in	In accordance to ANSI A 137.1
 Warpage edge	ASTM C-485	± 0.4% or ± 0.05 in	
 Thickness	ASTM C-499	RANGE: 0.040 inch max (1 mm)	In accordance to ANSI A 137.1
 Water absorption	ASTM C-373	≤ 0.5%	Passed "impervious tiles" Class P1
 Breaking strength	ASTM C-648	≥ 250 lbs (≥1113 N)	≥400 lbs
 Freeze thaw	ASTM C-1026	No damages	In accordance
 Chemical resistance	ASTM C-650	As reported	Unaffected
 MOHS hardness			6
 Dynamic Coefficient of Friction	ANSI A 326.3	Declare Classified	WET DOCF ≥0.42 Interior Wet

Average values referred to the last two years of production and related to the matte finish of the product. Values relate to the matte finish of the product and to tests carried out by certified external laboratories, whose results are available upon request. Be sure to use the same caliber tiles. Color reproductions may vary from actual products. * Due to the intrinsic nature of porcelain stoneware tiles, please note that the coefficient of friction may vary from one production lot to another. Caesar products can become slippery when wet. We recommend to always keep the surface dry.

WAVES

— ELEGANCE ACROSS SURFACES

COLOR-BODY PORCELAIN TILES
RECTIFIED - MATTE FINISH

MALIBÙ



VENICE



LAGUNA



PACIFIC



SIZES

24"x48"



24"x24"



12"x24"



6"x24"



DECORS

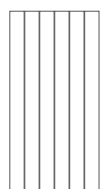

2"x24" stave
on 12"x24" sheet

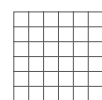

2"x2" mosaic
on 12"x12" sheet

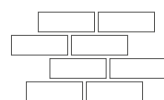

3"x8" brick mosaic
on 12"x16" sheet



design WAVES

Wall: Laguna brick 3"x8"



Floor: Malibù 24"x48"
Wall: Laguna brick 3"x8"



Floor: Pacific 6"x24", 12"x24"
Wall: Pacific brick 3"x8"
Desk: Pacific brick 3"x8"
Top: Anima Futura Majestic White 48"x109"7/16



Floor: Venice 12"x24"

MALIBÙ

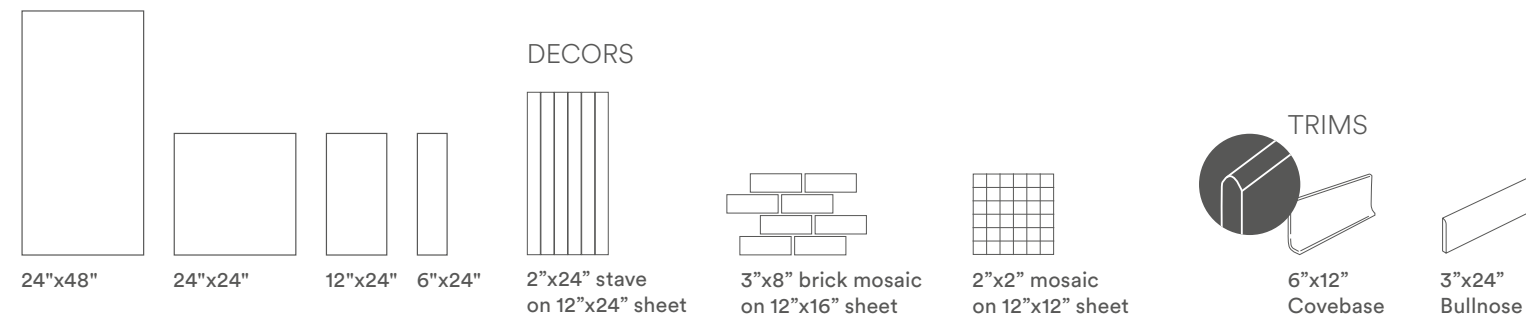

LAGUNA

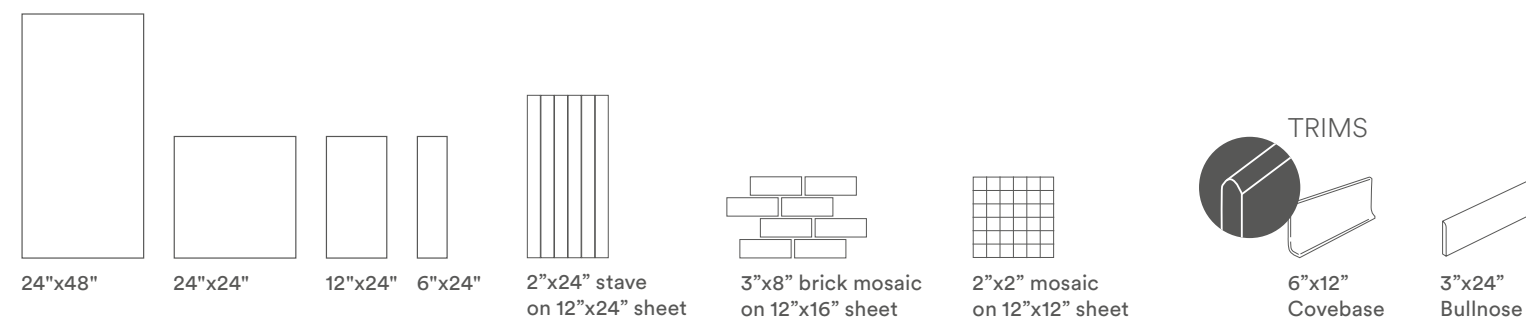
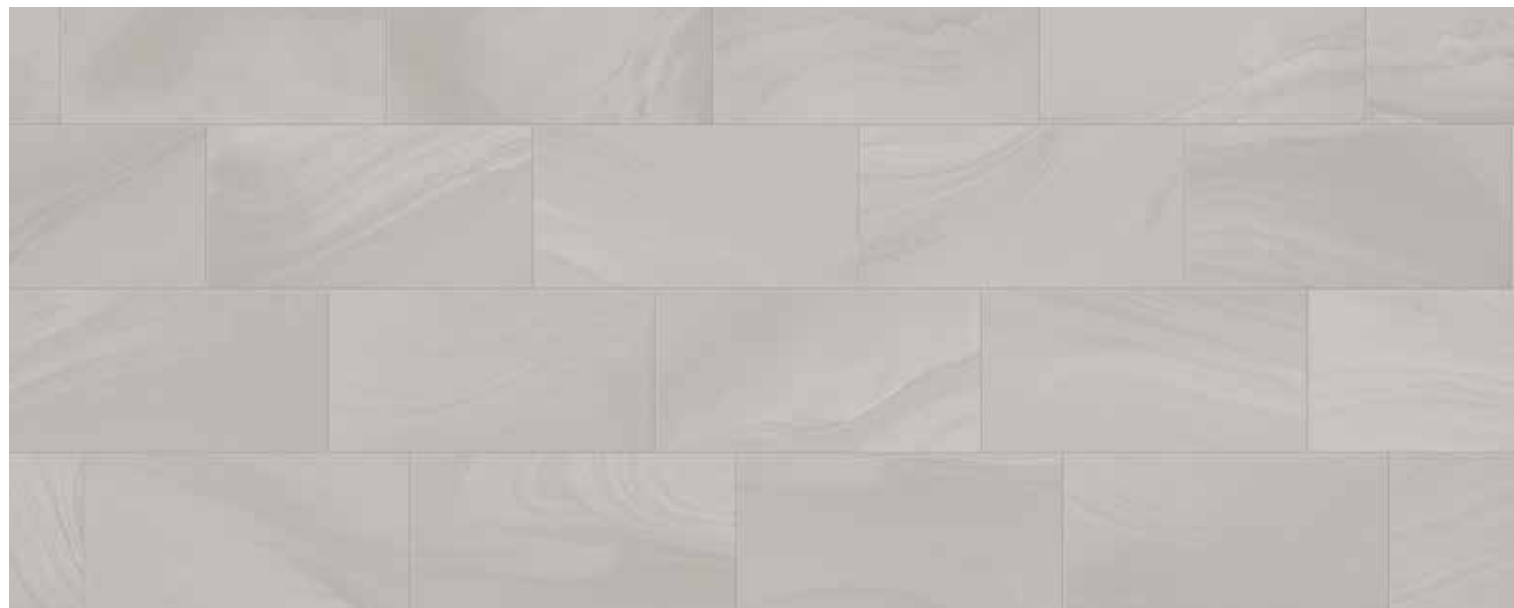

VENICE

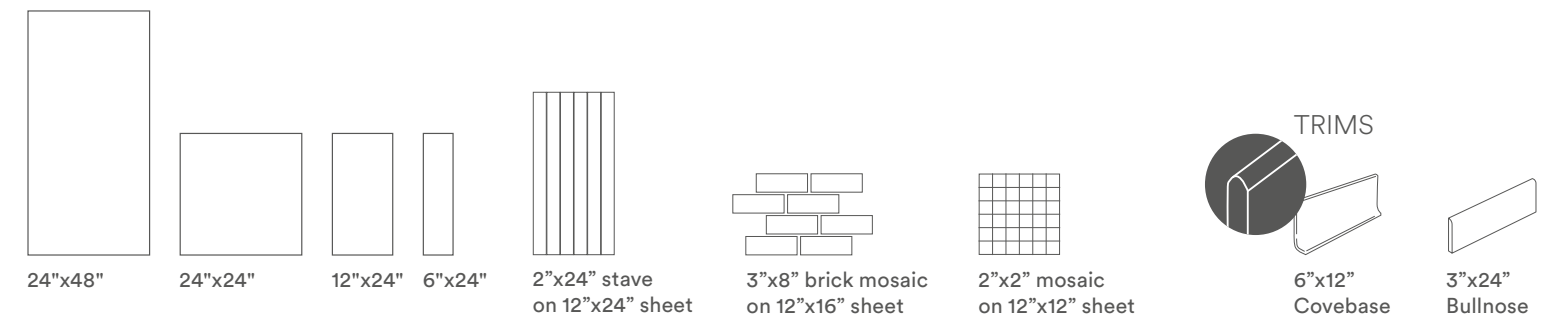

PACIFIC

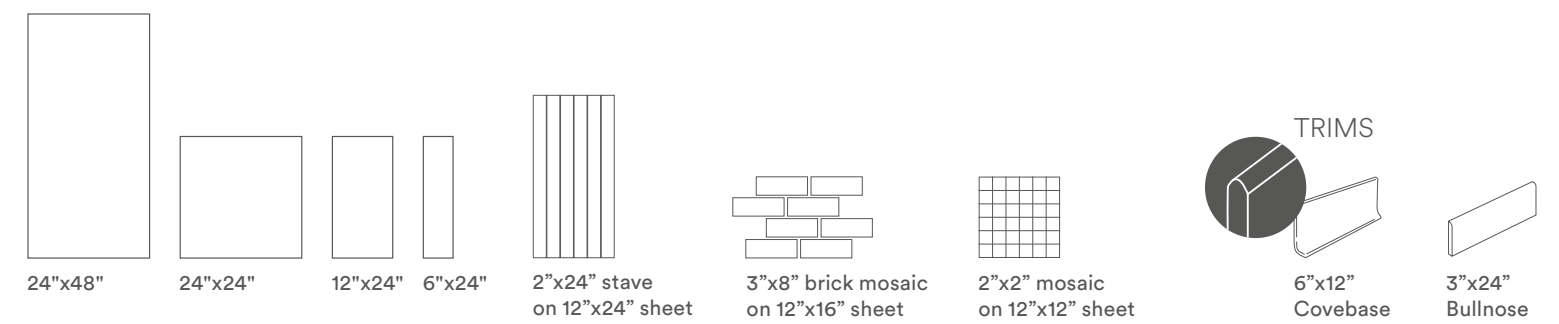

RANGE

						
	24"x48" 9 mm	24"x24" 9 mm	12"x24" 9 mm	6"x24" 9 mm	3"x24" Bullnose	6"x12" Covebase
MALIBÙ	●	●	●	●	●	●
VENICE	●	●	●	●	●	●
LAGUNA	●	●	●	●	●	●
PACIFIC	●	●	●	●	●	●

● Matte, rectified, squared, one caliber

Available in all colors



2"x24" stave
on 12"x24" sheet



3"x8" brick
on 12"x16" sheet

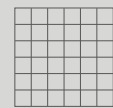

2"x2" mosaic
on 12"x12" sheet

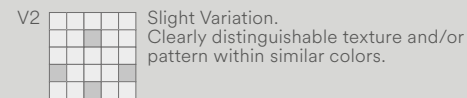

V2 Slight Variation.
Clearly distinguishable texture and/or
pattern within similar colors.

All sizes are nominal. For actual size
information please refer to page 177.

PACKAGING





Size	Box					Pallet					
	Inches	Pcs	Surface (sqf)	Surface (sqm)	Weigth (lbs)	Weigth (kg)	Boxes	Surface (sqf)	Surface (sqm)	Weigth (lbs)	Weigth (kg)
24"x 48"		2	15.51	1.44	~62.81	~28.4	35	542.85	50.43	~2200	~997
24"x 24"		3	11.63	1.08	~47.62	~21.6	40	465.00	43.2	~1904.77	~864
12"x 24"		7	13.56	1.26	~55.56	~25.2	40	542.51	50.4	~2222.24	~1008
6"x 24"		12	11.63	1.08	~47.62	~21.6	40	465.00	43.2	~1904.77	~864
2"x 24" Stave		10 sheets	9.69	0.9	~39.68	~18	36	348.75	32.4	~1428.58	~648
2"x 2" Mosaic		10 sheets	9.69	0.9	~39.68	~18	36	348.75	32.4	~1428.58	~648
3"x8" Brick		10 sheets	12.05	1.12	~52.91	~24	20	241	22.4	~1058.21	~480

We recommend you a 2/3 mm grout joint to simplify the laying and optimize the naturalness of the final result. In order to favour the ordinary maintenance procedures, it is recommended to carry out an acid wash of the surface after 48 hours from grout filling using an acid agent specific for porcelain stoneware tiles.

Caesar Ceramics USA reserves the right to change the products presented in this catalogue at any time.

Tones of samples are indicative











For information about installation and cleaning of Caesar products, please consult our general catalogue or the website www.caesarceramicsusa.com. Color reproductions may vary from actual products. Caesar reserves the right to modify the products illustrated in this catalogue for reasons of production or to improve quality. Samples are purely indicative. Packaging and weights may vary for production reasons. Contact our sales department when ordering. In case of running pattern installation, Caesar recommends a maximum 33% offset. Caesar warrants that our products meet or exceed the requirements of ANSI, specification ANSI A137.1: 2012, as shown in our Tile Performance Data sheets.

V0		Very Uniform appearance. Pieces of the same shade value are very uniform and smooth in texture. They can be measured for small color differences and are in compliance with the color uniformity requirements of tables 6-10 (ANSI A137.1-2012)
V1		Uniform Appearance. Differences among pieces from the same production run are minimal.
V2		Slight Variation. Clearly distinguishable texture and/or pattern within similar colors.
V3		Moderate Variation. While the colors and/or textures present on a single piece of tile will be indicative of the colors and/or texture to be expected on the other tiles, the amount of colors and/or texture on each piece may vary significantly. It is recommended that the range be viewed before selection.
V4		Substantial Variation. Random color and/or texture differences from tile to tile, so that one tile may have totally different colors and/or textures from that on other tiles. Thus, the final installation will be unique. It is recommended that the range be viewed before selection.

WAVES TILE PERFORMANCE DATA

Color-body porcelain stoneware tiles are produced minimizing the color difference between the glaze and the body. Nevertheless, the design is visible only on the surface.



TECHNICAL FEATURE	METHOD	VALUE REQUIRED ANSI A 137.1	CAESAR AVERAGE VALUE
 Facial dimension	ASTM C-499	± 0.25% or ± 0.03 in	In accordance to ANSI A 137.1
 Wedging	ASTM C-502	± 0.25% or ± 0.03 in	
 Warpage diagonal	ASTM C-485	± 0.4% or ± 0.07 in	
 Warpage edge	ASTM C-485	± 0.4% or ± 0.05 in	
 Thickness	ASTM C-499	RANGE: 0.040 inch max (1 mm)	In accordance to ANSI A 137.1
 Water absorption	ASTM C-373	≤ 0.5%	Passed "impervious tiles" Class P1
 Breaking strength	ASTM C-648	≥ 250 lbs (≥1113 N)	≥400 lbs
 Freeze thaw	ASTM C-1026	No damages	In accordance
 Chemical resistance	ASTM C-650	As reported	Unaffected
 MOHS hardness			6
 Dynamic Coefficient of Friction	ANSI A 326.3	Declare Classified	WET DOCF ≥0.42 Interior Wet

Average values referred to the last two years of production and related to the matte finish of the product. Values relate to the matte finish of the product and to tests carried out by certified external laboratories, whose results are available upon request. Be sure to use the same caliber tiles. Color reproductions may vary from actual products. * Due to the intrinsic nature of porcelain stoneware tiles, please note that the coefficient of friction may vary from one production lot to another. Caesar products can become slippery when wet. We recommend to always keep the surface dry.

WHISPER

— THE PURE BEAUTY OF NATURAL WOOD

COLOR-BODY PORCELAIN TILES
RECTIFIED - MATTE FINISH

BREEZE



ASH



SAND



FOREST



SIZES

8"x40"



8"x40" CHEVRON





Floor: Sand 8"x40", Origin Canyon 24"x48"



Wall: Sand 8"x40"
Floor: Forest 8"x40"

wood WHISPER



Wall: Listel Mosaic Forest 2.5"x19"
Floor: Breeze 8"x40"



Floor: Ash 8"x40", Chevron Ash 8"x40"

BREEZE



8"x40"



8"x40" CHEVRON

TRIMS

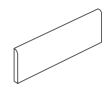

2.5"x20"
Bullnose

Available upon request

SAND



8"x40"



8"x40" CHEVRON

TRIMS

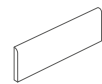

2.5"x20"
Bullnose

Available upon request

FOREST



8"x40"



8"x40" CHEVRON

TRIMS

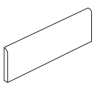

2.5"x20"
Bullnose

Available upon request

ASH



8"x40"



8"x40" CHEVRON

TRIMS

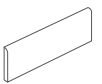

2.5"x20"
Bullnose

Available upon request

RANGE

	8"x40" 9 mm	8"x40" 9 mm	2.5"x20" Bullnose (Available upon request)
BREEZE	●	●	●
ASH	●	●	●
SAND	●	●	●
FOREST	●	●	●

● Matte, rectified, squared, one caliber

V2  Slight Variation. Clearly distinguishable texture and/or pattern within similar colors.

All sizes are nominal. For actual size information please refer to page 177.

PACKAGING





Size	Box		Pallet							
	Pcs	Surface (sqf)	Surface (sqm)	Weigth (lbs)	Weigth (kg)	Boxes	Surface (sqf)	Surface (sqm)	Weigth (lbs)	Weigth (kg)
8"x40"	6	12.92	1.2	~56.88	~25.8	36	465.00	43.20	~2,047.63	~928.8
8"x40" Chevron	6	10.33	0.96	~43.39	~19.68	30	310.00	28.80	~1,301.60	~590.4

We recommend you a 2/3 mm grout joint to simplify the laying and optimize the naturalness of the final result. In order to favour the ordinary maintenance procedures, it is recommended to carry out an acid wash of the surface after 48 hours from grout filling using an acid agent specific for porcelain stoneware tiles.

Caesar Ceramics USA reserves the right to change the products presented in this catalogue at any time.

Tones of samples are indicative











For information about installation and cleaning of Caesar products, please consult our general catalogue or the website www.caesarceramicsusa.com. Color reproductions may vary from actual products. Caesar reserves the right to modify the products illustrated in this catalogue for reasons of production or to improve quality. Samples are purely indicative. Packaging and weights may vary for production reasons. Contact our sales department when ordering. In case of running pattern installation, Caesar recommends a maximum 33% offset. Caesar warrants that our products meet or exceed the requirements of ANSI, specification ANSI A137.1: 2012, as shown in our Tile Performance Data sheets.

V0  Very Uniform appearance. Pieces of the same shade value are very uniform and smooth in texture. They can be measured for small color differences and are in compliance with the color uniformity requirements of tables 6-10 (ANSI A137.1-2012)	V1  Uniform Appearance. Differences among pieces from the same production run are minimal.	V2  Slight Variation. Clearly distinguishable texture and/or pattern within similar colors.
V3  Moderate Variation. While the colors and/or textures present on a single piece of tile will be indicative of the colors and/or texture to be expected on the other tiles, the amount of colors and/or texture on each piece may vary significantly. It is recommended that the range be viewed before selection.	V4  Substantial Variation. Random color and/or texture differences from tile to tile, so that one tile may have totally different colors and/or textures from that on other tiles. Thus, the final installation will be unique. It is recommended that the range be viewed before selection.	

WHISPER TILE PERFORMANCE DATA

Color-body porcelain stoneware tiles are produced minimizing the color difference between the glaze and the body. Nevertheless, the design is visible only on the surface.



TECHNICAL FEATURE	METHOD	VALUE REQUIRED ANSI A 137.1	CAESAR AVERAGE VALUE
 Facial dimension	ASTM C-499	± 0.25% or ± 0.03 in	In accordance to ANSI A 137.1
 Wedging	ASTM C-502	± 0.25% or ± 0.03 in	
 Warp page diagonal	ASTM C-485	± 0.4% or ± 0.07 in	
 Warp page edge	ASTM C-485	± 0.4% or ± 0.05 in	
 Thickness	ASTM C-499	RANGE: 0.040 inch max (1 mm)	In accordance to ANSI A 137.1
 Water absorption	ASTM C-373	≤ 0.5%	Passed "impervious tiles" Class P1
 Breaking strength	ASTM C-648	≥ 250 lbs (≥1113 N)	≥400 lbs
 Freeze thaw	ASTM C-1026	No damages	In accordance
 Chemical resistance	ASTM C-650	As reported	Unaffected
 MOHS hardness			6
 Dynamic Coefficient of Friction	ANSI A 326.3	Declare	WET DOCF ≥0.42
		Classified	Interior Wet

Average values referred to the last two years of production and related to the matte finish of the product. Values relate to the matte finish of the product and to tests carried out by certified external laboratories, whose results are available upon request. Be sure to use the same caliber tiles. Color reproductions may vary from actual products. * Due to the intrinsic nature of porcelain stoneware tiles, please note that the coefficient of friction may vary from one production lot to another. Caesar products can become slippery when wet. We recommend to always keep the surface dry.

AEXTRA20

— PORCELAIN TILE PAVERS



RECTIFIED TILE

COLOR-BODY PORCELAIN TILES
RECTIFIED - MATTE FINISH

Caesar Aextra20 porcelain stoneware slabs are monolithic in 20mm thickness, are perfectly rectified and squared and have an anti-slip surface finish.

STONE LOOK

PENNSYLVANIA BLUE



PENNSYLVANIA GRAY



TITANIO



GEA



GRAUSTEIN



ICE



WIND



SIZES

24"x48"



24"x24"



12"x24"



12"x12"



THICKNESS



3/4" [2cm]





Floor: Gea 24"x48", Gea 24"x24"



Floor: Wind 24"x24"

Floor: Pennsylvania Blue 24"x24" . 12"x24" . 12"x12"



Floor: Pennsylvania Gray 24"x24"



Floor: Titanio 24"x24", Xgrip Titanio 12"x24", Top Titanio12"x24", Top End Titanio 12"x24" - Revive Ginger 8"x40"



Floor: Titanio 24"x24", Xgrip Titanio 12"x24", Top Titanio12"x24", Top End Titanio 12"x24" - Revive Ginger 8"x40"

outdoor AEXTRA20



Floor: Graustein 24"x24"



Floor: Gea 24"x24"

JAPANESE STEPS

ORIGAMI

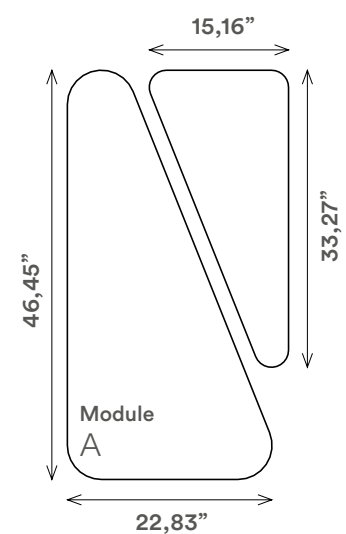

Origami. A design of triangular geometries, with evocative bevelled edges, inspires the creation of contemporary and refined paths in the green.

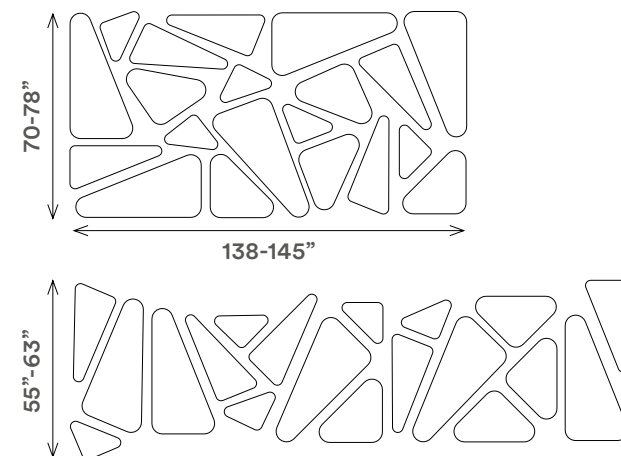
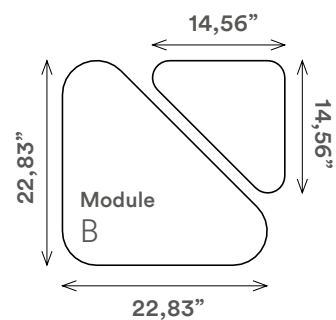

Installation Guidelines for Origami. For a surface of 8 sqm (4x2 m), it is recommended to use 5 modules A and 5 modules B, for a total of 20 tiles, with an indicative joint of 8 cm.

ENSO



Enso. Irregular circular shapes provide inspiration for designing harmonious paths, perfectly integrated into the landscape.

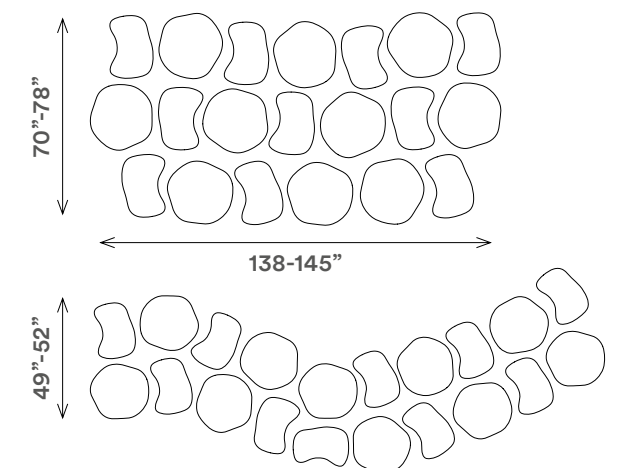
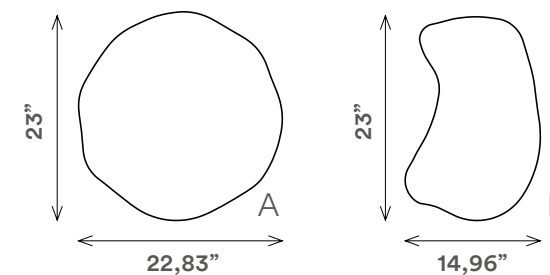

Installation Guidelines for Enso. For a surface of 8 sqm (4x2 m), it is recommended to use 10 tiles A and 10 tiles B, with an indicative joint ranging between 6 and 12 cm.

ADVANTAGES OF AEXTRA20 PAVERS



INSTALLATION ONTO GRASS

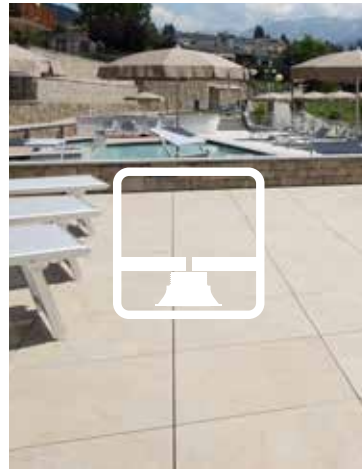

RAISED INSTALLATION



INSTALLATION ONTO GRAVEL/SAND

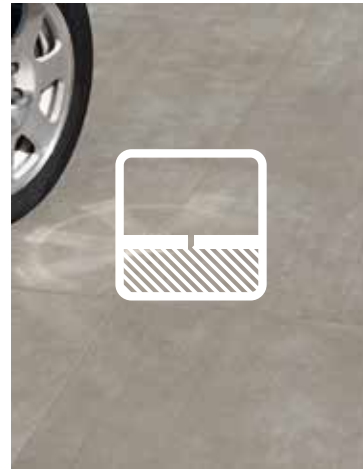

INSTALLATION WITH ADHESIVES

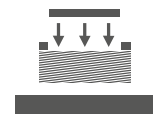

QUICK AND EASY TO INSTALL



REUSABLE



AVOIDING THE RISK OF BREAKING AND CRACKS

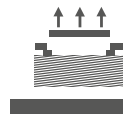

EASY TO INSPECT AND REMOVABLE



CORRECTING PLANARITY DEFECTS

TRIMS

Available in all the Aextra20 colors

1 12"x24" XSTEP

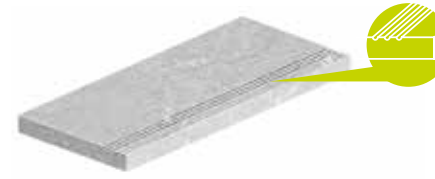

2 12"x24" XSTEP CORNERS (INTERNAL)

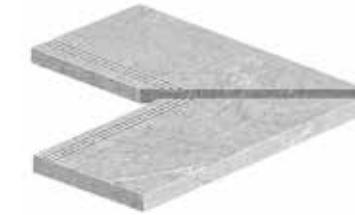

3 12"x24" XSTEP CORNERS (EXTERNAL)



4 12"x24" ROUND



5 12"x24" ROUND CORNERS (INTERNAL)



6 12"x24" ROUND CORNERS (EXTERNAL)



7 12"x24" XGRIP

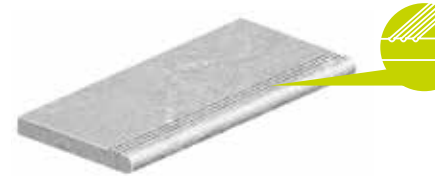

8 12"x24" XGRIP CORNERS (INTERNAL)

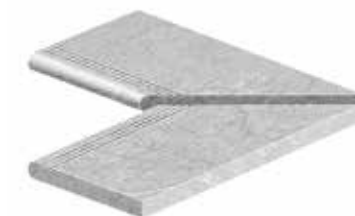

9 12"x24" XGRIP CORNERS (EXTERNAL)



10 6"x24" RISER



11 12"x24" TOP



12 12"x24" TOP END



SOME EXAMPLES OF INSTALLATION PATTERNS

AVAILABLE ONLY IN PENNSYLVANIA COLORS

Recommended Joint width 4mm (approximately 5/32")

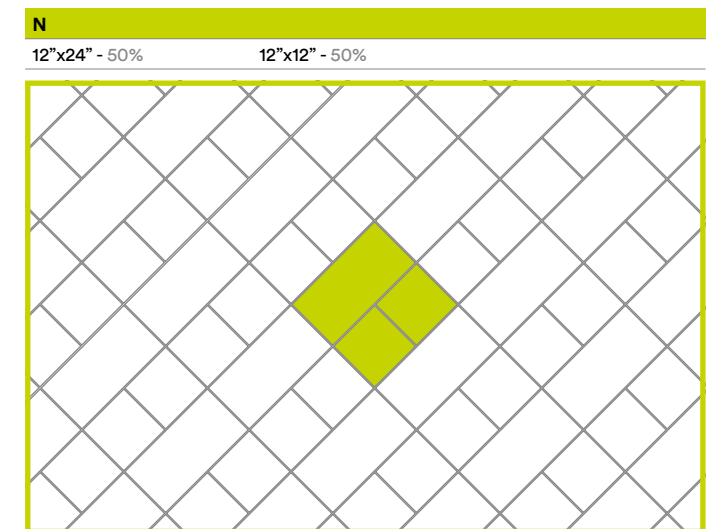
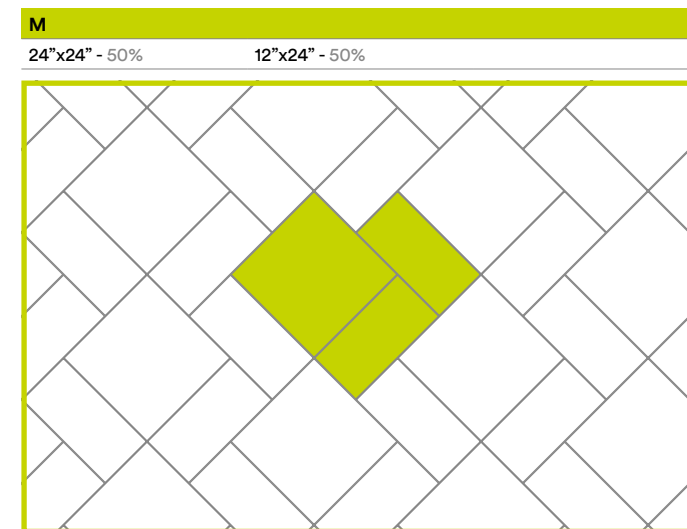
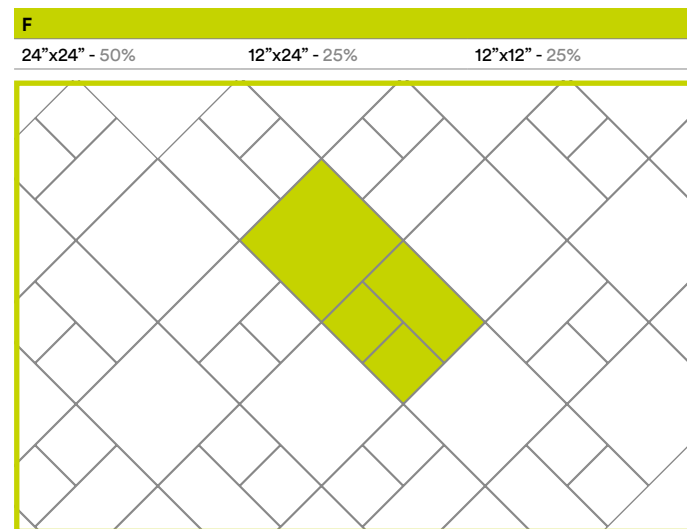
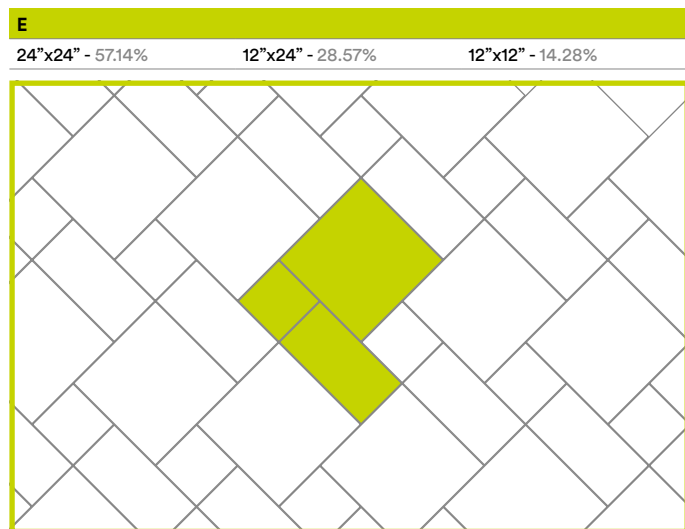
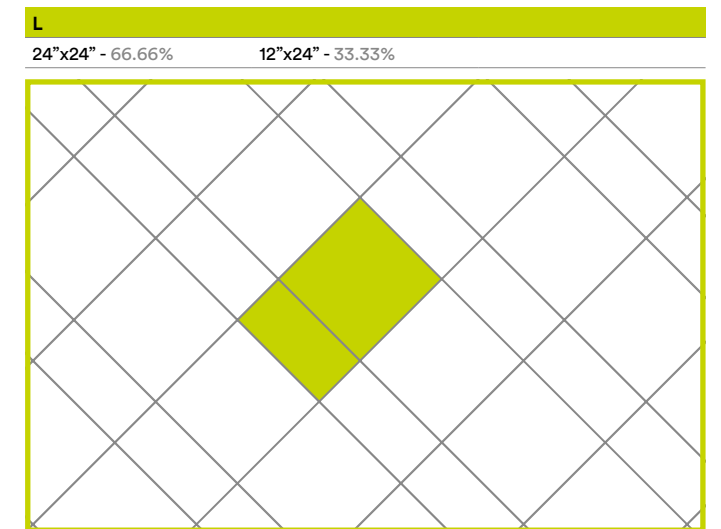
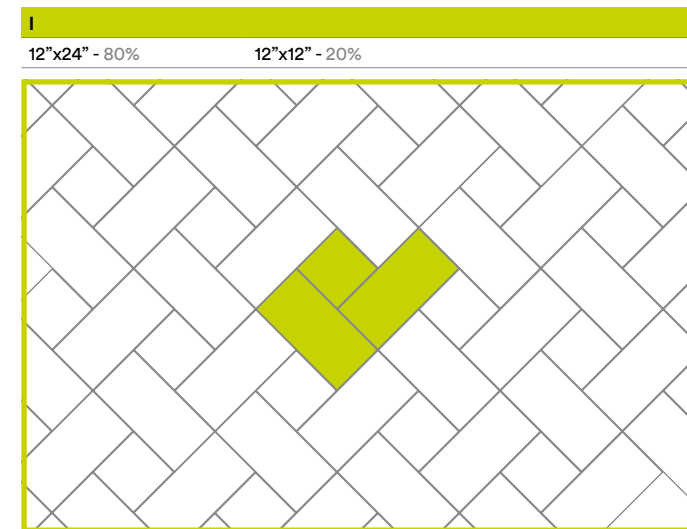
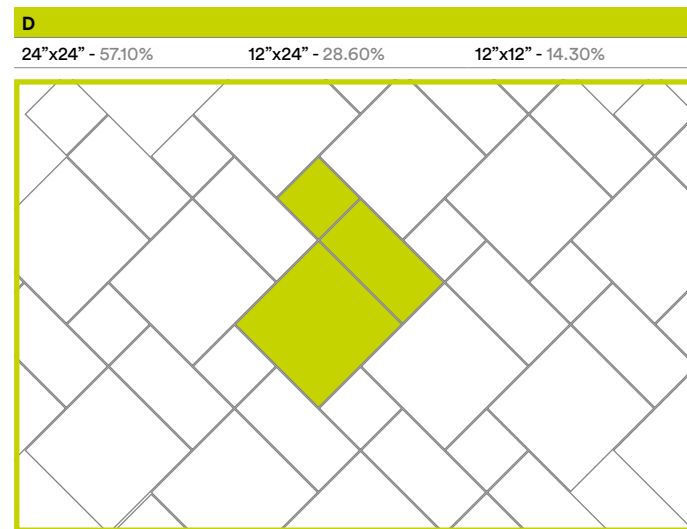
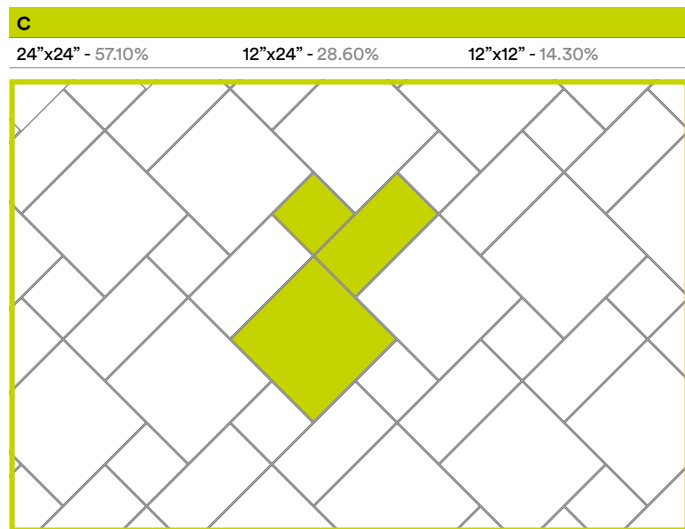
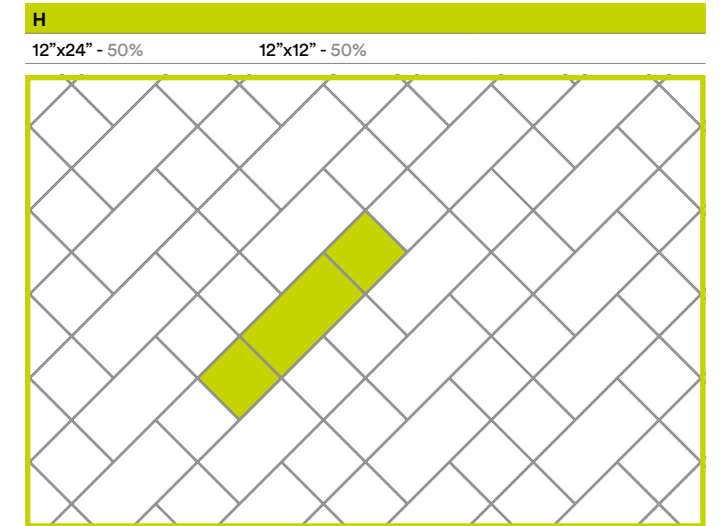
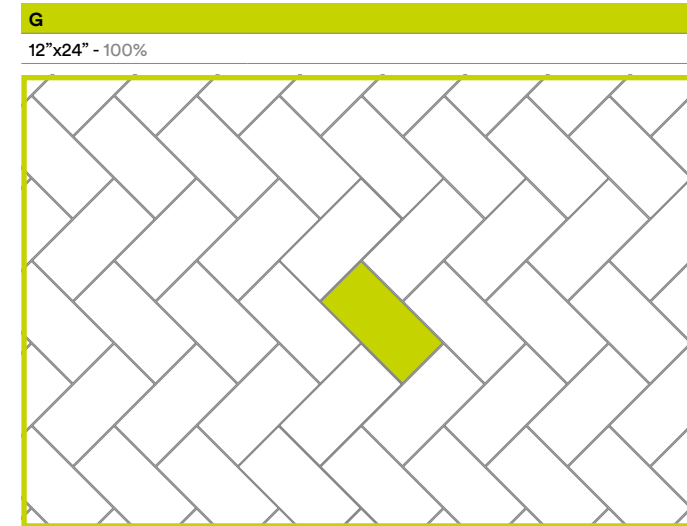
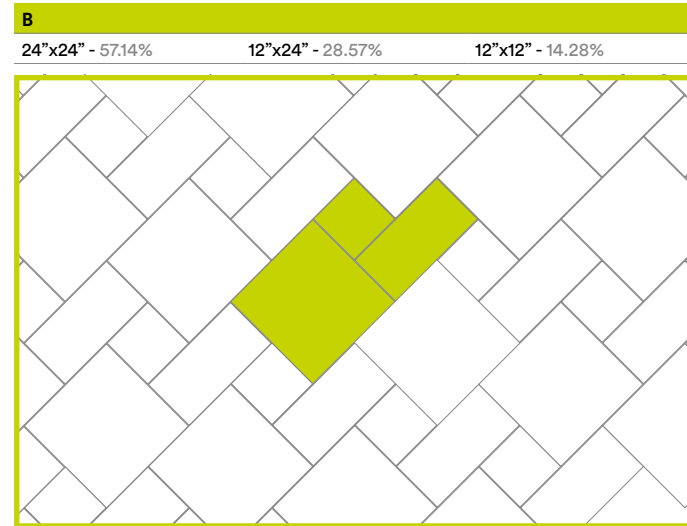
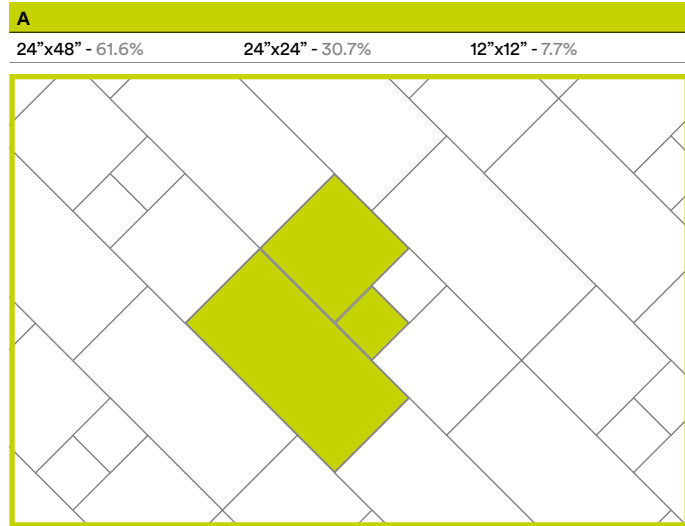

RANGE

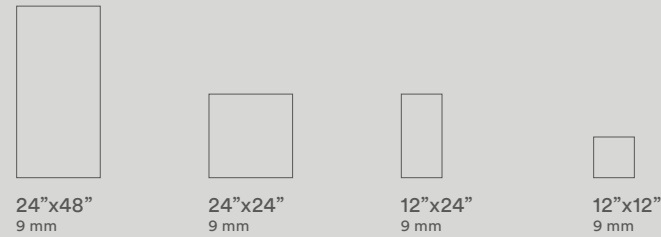

PENNSYLVANIA BLUE	●	●	●
PENNSYLVANIA GRAY	●	●	●
TITANIO	●	●	●
GEA	●	●	●
GRAUSTEN	●	●	●
ICE	●	●	●
WIND	●	●	●

TRIMS
12"x24", 12"x12" are available in all colors for >1000 pieces orders

PACKAGING

Size	Box		Pallet							
	Pcs	Surface (sqf)	Surface (sqm)	Weight (lbs)	Weight (kg)	Boxes	Surface (sqf)	Surface (sqm)	Weight (lbs)	Weight (kg)
24"x48"	1	7.75	0.72	~70.54	~32	32	248.00	23.04	~2.257.28	~1024
24"x24"	2	7.75	0.72	~70.54	~32	30	232.50	21.60	~2.116.20	~959.9
12"x24"	4	7.75	0.72	~70.54	~32	32	248	23.04	~2.257.28	~1.024
12"x 12"	5	4.84	0.45	~39.46	~17.9	30	145.2	13.5	~1.183.8	~537

If the application of the 3/4" inch (20 mm) slabs foresees the ceramic product used in structural installations, the project engineer and/or customer must carefully assess the project requirements with regard to the technical specifications of the slabs. To prevent the risk of damage or injury, the manufacturer recommends:

- With regard to a raised floor installation a ceramic slab may fracture on impact if a heavy object falls on it from any significant height. Therefore the manufacturer recommends to check the specific intended use before starting the installation and to follow table for raised installation provided below. In certain conditions, reinforcing must be applied on the back of the slabs (double glass fibre net or a galvanized steel sheet) supplied and applied by the manufacturer;
- With reference to any dry installation system of flooring above the ground level, the manufacturer recommends to comply with local regulations and conditions of use with regard to wind-load, loadbearing, seismic events, etc. Failure to comply with these recommendations may lead to improper use of the product and could cause serious damage or injury.

Caesar Ceramics USA reserves the right to change the products presented in this catalogue at any time.

Tones of samples are indicative

For information about installation and cleaning of Caesar products, please consult our general catalogue or the website www.caesarceramicsusa.com. Color reproductions may vary from actual products. Caesar reserves the right to modify the products illustrated in this catalogue for reasons of production or to improve quality. Samples are purely indicative. Packaging and weights may vary for production reasons. Contact our sales department when ordering. In case of running pattern installation, Caesar recommends a maximum 33% offset. Caesar warrants that our products meet or exceed the requirements of ANSI, specification ANSI A137.1: 2012, as shown in our Tile Performance Data sheets.

INSTRUCTIONS FOR RAISED FLOOR INSTALLATION

RAISE OF THE FOOT PLAN

INCHES	MM	Up to 3/4 inch	Above 3/4 inch
24"x24"	610x610	4 supports/slab (0.32 supports/sqf - 3.4 supports/m2)	Please contact Caesar Ceramics Usa (Caesartech dept.)

V0 Very Uniform appearance. Pieces of the same shade value are very uniform and smooth in texture. They can be measured for small color differences and are in compliance with the color uniformity requirements of tables 6-10 (ANSI A137.1-2012)

V1 Uniform Appearance. Differences among pieces from the same production run are minimal.

V2 Slight Variation. Clearly distinguishable texture and/or pattern within similar colors.

V3 Moderate Variation. While the colors and/or textures present on a single piece of tile will be indicative of the colors and/or texture to be expected on the other tiles, the amount of colors and/or texture on each piece may vary significantly. It is recommended that the range be viewed before selection.

V4 Substantial Variation. Random color and/or texture differences from tile to tile, so that one tile may have totally different colors and/or textures from that on other tiles. Thus, the final installation will be unique. It is recommended that the range be viewed before selection.

AEXTRA20 TILE PERFORMANCE DATA

Color-body porcelain stoneware tiles are produced minimizing the color difference between the glaze and the body. Nevertheless, the design is visible only on the surface.



TECHNICAL FEATURE	METHOD	VALUE REQUIRED ANSI A 137.1	CAESAR AVERAGE VALUE
Facial dimension	ASTM C-499	± 0.25% or ± 0.03 in	
Wedging	ASTM C-502	± 0.25% or ± 0.03 in	
Warp page diagonal	ASTM C-485	± 0.4% or ± 0.07 in	In accordance to ANSI A 137.1
Warp page edge	ASTM C-485	± 0.4% or ± 0.05 in	
Thickness	ASTM C-499	RANGE: 0.040 inch max (1 mm)	In accordance to ANSI A 137.1
Water absorption	ASTM C-373	≤ 0.5%	Passed "impervious tiles" Class P1
Breaking strength	ASTM C-648	≥ 250 lbs (≥1113 N)	≥3000 lbs
Freeze thaw	ASTM C-1026	No damages	In accordance
Chemical resistance	ASTM C-650	As reported	Unaffected
MOHS hardness			6
Dynamic Coefficient of Friction	ANSI A 326.3	Declare	WET DOCF ≥0.55
		Classified	Exterior Wet

Average values referred to the last two years of production and related to the matte finish of the product. Values relate to the matte finish of the product and to tests carried out by certified external laboratories, whose results are available upon request. Be sure to use the same caliber tiles. Color reproductions may vary from actual products. * Due to the intrinsic nature of porcelain stoneware tiles, please note that the coefficient of friction may vary from a production lot to another. Caesar products can become slippery when wet. We recommend to always keep the surface dry.

DECORS

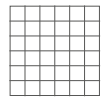

2"x2"
mosaic

BOND



COSMIX

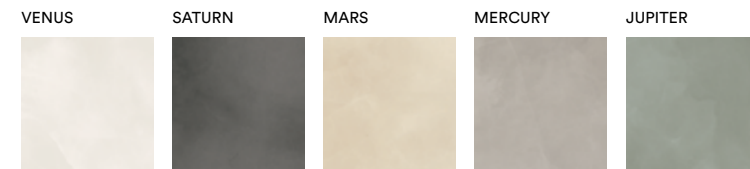

CRETE



FOUNDRY26



GEMSTONE



LINK

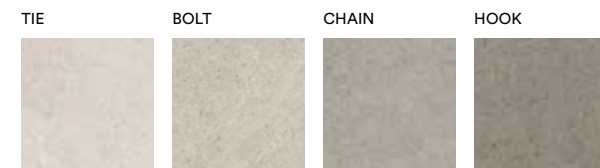

ORIGIN

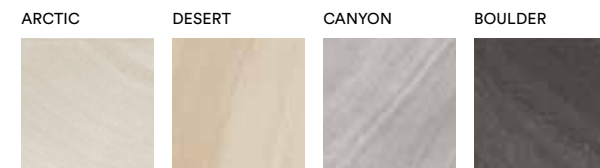

PLACE

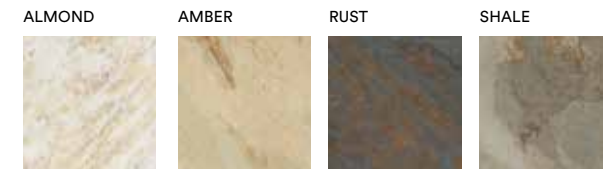

RUN

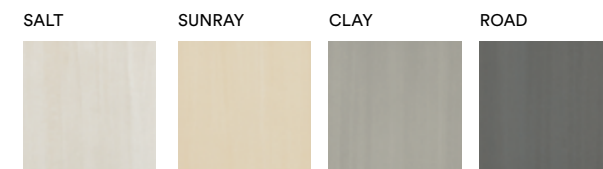

SELECT

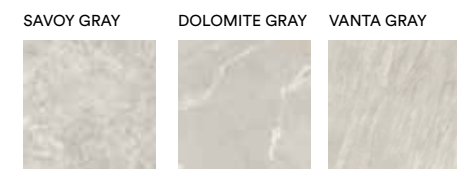

STONeways

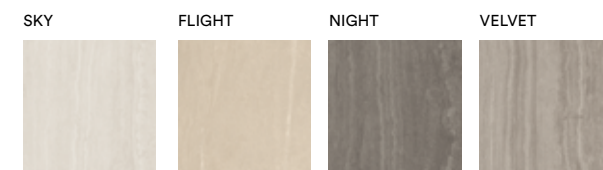

STYLE

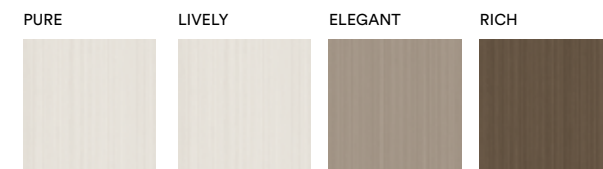

WAVES

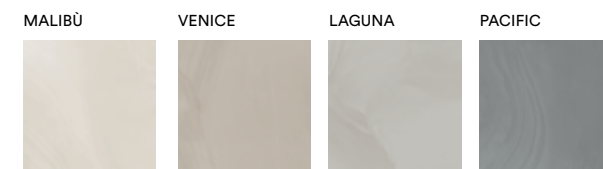

DECORS



1.3"x3.8"
herringbone mosaic

GEMSTONE

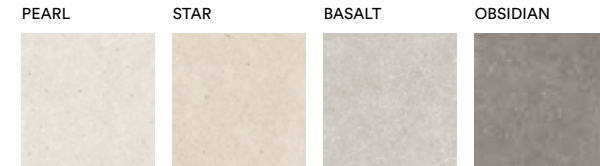

STONEWAYS

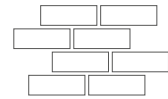
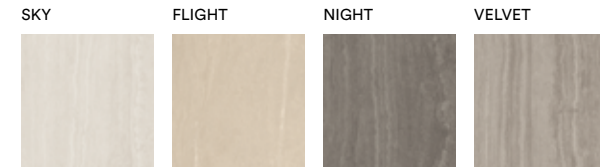

3"x8"
brick mosaic

ORIGIN

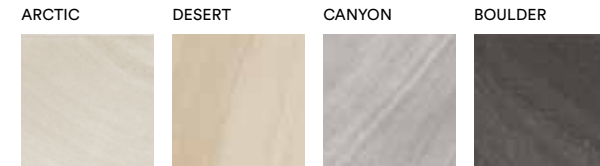

WAVES

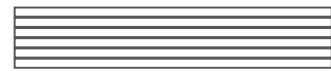
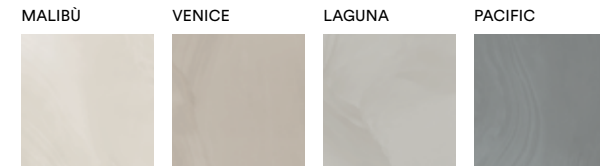

8"x40"
stave

NATURE

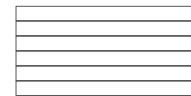

2"x24"
stave

WAVES

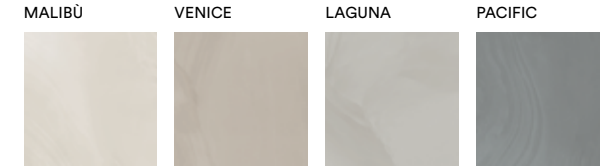

12"x24"
stave scored

GEMSTONE

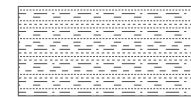
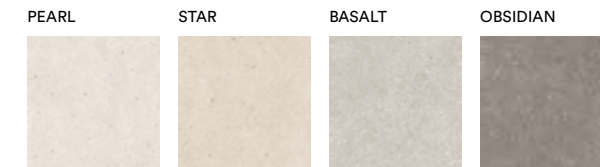

12"x24"
3d motion

CRETE

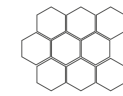
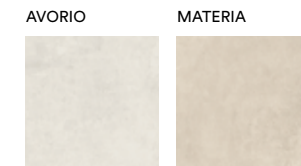

4.4"x3.8"
hexagon mosaic

COSMIX

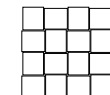
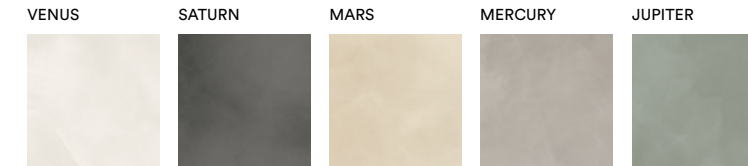

2.72"x3"
basket

SELECT

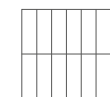

2"x6" mosaic
on 12"x12" sheet

CRETE



3"x3.5"
hexagon mosaic

GEMSTONE



SELECT



2"x6.5"
stretch mosaic

BOND



PATHWAY

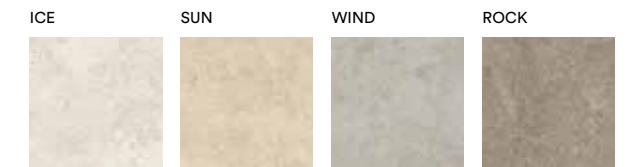



CLEANING PROCEDURES

FINAL CLEANING AFTER INSTALLATION

A few hours after grouting, as soon as the grout starts to dry and becomes opaque, sweep the floor. Within 48 hours from grouting and before the grout hardens definitively, wet the floor with an acid and buffered solution. Dilution depends on the type of surface (smooth or textured). Spread the solution containing acid especially made for stoneware using a mop or a rotary brush for large surfaces, and featuring suitable discs, and let the solution work for a few minutes. Rinse with warm water and clean cloths and repeat several times until all stains and residues have been eliminated. Make sure to change rinsing water several times. Complete by drying. Prevent contact of the acid solution with other materials (metal, marble, etc.).

ATTENTION!!

Epoxy-based grout cannot be cleaned when it has completely hardened other than mechanically with risks to the surface of the tiles. For more information and recommendations, consult the grout manufacturer. Care must be taken on inlaid, polished and anti-slip products; for the latter in particular, the use of a floor-washing machine combined with the action of an acid detergent helps reach the spaces between adjacent tiles and cleans them properly. If such a cleaning procedure is not carried out, or if such cleaning is carried out too late, the grout residue creates an extremely absorbent film, which holds dirt, making the surface difficult to clean: in this case, Caesar ceramics USA, INC. will not be liable for any damage caused to the surface.

CLEANING AND CARE

If the cleaning rules after installation are followed, routine maintenance, i.e. everyday cleaning to remove dirt from traffic and general use of the tiled surface, is reasonably easy. We would like to remind you that porcelain stoneware is a product with excellent technical features which allow for the highest grade of mechanical wear and resistance to acids (except for hydrofluoric acid and its derivatives) and alkalis, features which are added to a high aesthetic quality. Porcelain stoneware has a low absorption level, another intrinsic characteristic of the product. As detailed in the technical sheets, absorption levels are very low in the production process Caesar Ceramics Usa, Inc. adopts, and all our products will achieve the best results for any kind of specific application. Ordinary maintenance must be carried out using specialist detergents to remove stains but these detergents must not leave a wax, film or membrane residue. Rinsing well with plenty of clean water is a fundamental part of the cleaning procedure, therefore we advise against the use of products which state that they "do not need rinsing".

We would like to inform you that, the above mentioned standards do not cover rubber stains (shoes, heels, mats, etc...) especially where these kinds of stains are frequent: therefore, Caesar Ceramics Usa, Inc. will not be held liable for any such damage to the surface of these products. All types of surface of the Caesar Ceramics Usa, Inc. range can be washed with clean water or water and up to 50% of bleach or alcohol. We recommend periodical cleaning with basic products or a micro-foaming basic product for porcelain stoneware, followed by thorough rinsing and drying.

HEAVY-DUTY CLEANING

Any stains or marks can be removed quite easily since porcelain stoneware has very low absorption properties and resists acids and bases. Depending on the type of stain, you can use:
 - ACIDS for INORGANIC stains,
 - BASES for ORGANIC stains,
 - SOLVENTS for SYNTHETIC stains.

The use of common aggressive acids (such as muriatic acid for instance) must be avoided. These products remove residues of grout but also irreparably damage the grout within the joint. Also pay attention to all products containing HYDROFLUORIC ACID (HF) SINCE THEY IRREPARABLY DAMAGE ALL CERAMIC SURFACES.

WARNING

The above suggestions are a result of research, laboratory tests and several years' experience. However, the cleaning features of the materials may vary significantly according to the different installation methods, conditions of use, types of surface and destination. As a general rule, the higher the anti-slip values of the tiles are, the greater cleaning inconveniences may arise. The professional operator in charge of maintenance and cleaning shall always check the surface condition before proceeding with any cleaning and/or maintenance operation (we would suggest to test some tiles before installation). Caesar Ceramics Usa, Inc. declines any liability with reference to cleaning and maintenance operations in case of heavy conditions of use (such as mechanical workshop or spaces presenting oily residues or tire marks), bad installation work or wrong cleaning operations, it is agreed that Caesar Ceramics Usa, Inc. shall not be liable for any event, damage or defect due to wrong installation of the tiles, faulty cleaning and maintenance operations or inadequate choice of the type of material to be laid or of the adhesives used in a certain destination of use.

Type of stain	Cleaning agent	Detergents	Detergent manufacturer
INORGANIC STAINS			
Cement Carbon Calcium Efflorescence Chalk Metallic residues Rust Cement based grout, Coloured grout Wall paint	Acid	ETERDEK	UNITED STATES > Fila Chemicals USA Corp. 10800 N.W. 21 st. Street #170 Miami, FL 33172 USA Tel: +1 305 513 0708 filausa@filasolutions.com
		KERANET (LIQUID) or Similar	MAPEI Americas headquarters 1144 E. Newport Center Drive Deerfield Beach, Florida 33442
ORGANIC STAINS			
Coca Cola, Ice Cream, Coffee, Wine, Beer Animal fats Vegetable fats Mustard, Mayonnaise Ketchup, Jam, Marmelade, Linseed oil, lipstick, wax	Alkaline and Neutral	PS87	UNITED STATES > Fila Chemicals USA Corp. 10800 N.W. 21 st. Street #170 Miami, FL 33172 USA Tel: +1 305 513 0708 filausa@filasolutions.com
		FILACLEANER	UNITED STATES > Fila Chemicals USA Corp. 10800 N.W. 21 st. Street #170 Miami, FL 33172 USA Tel: +1 305 513 0708 filausa@filasolutions.com
		Ammonium	Universal
Residual rings of organic nature	Saline Solution	Sodium hypochloride (bleach for white laundry)	Universal
Silicone oils Machine oil Resins and glazes Coal and natural rubber Inks and markers	Solvent	Filasolv or similar	UNITED STATES > Fila Chemicals USA Corp. 10800 N.W. 21 st. Street #170 Miami, FL 33172 USA Tel: +1 305 513 0708 filausa@filasolutions.com
		Aceton	Universal
		Nitro - Thiner	Universal
		Turpentine	Universal
		Trichlorethylene	Universal
Tire		Hand Cleanser	Universal
		Cif ammoniacal	Universal

WHERE QUALITY MEETS DESIGN

The elegant design and carefully crafted details of Caesar USA products are totally integrated into a sound material with a superior performance. Caesar has always focused on porcelain tiles with excellent technical properties which, over the years, have acquired more value by virtue of aesthetic interpretations that have become more diverse and refined, without losing the high quality standards that are part of the company's culture.

• CAESAR •
CERAMICS USA



ACTUAL SIZES FOR RECTIFIED MATERIAL

NOMINAL SIZE INCHES	MM	ACTUAL SIZE INCHES	MM
24"x48"	610x1220	23 ^{15/32"} x47 ^{5/16"}	596x1195
24"x24"	610x610	23 ^{15/32"} x23 ^{15/32"}	596x596
12"x24"	305x610	11 ^{11/16"} x23 ^{15/32"}	297x596
6"x24"	152x610	5 ^{45/64"} x23 ^{15/32"}	145x596
6"x12"	152x305	5 ^{45/64"} x11 ^{11/16"}	145x297
8"x40"	203x1016	7 ^{23/32"} x39 ^{1/8"}	196x995

ACTUAL SIZES FOR RECTIFIED MATERIAL - 3/4" THICKNESS

NOMINAL SIZE INCHES	MM	ACTUAL SIZE INCHES	MM
24"x24"	610x610	23 ^{35/64"} x23 ^{35/64"}	598x598

ACTUAL SIZES FOR NON-RECTIFIED MATERIAL

NOMINAL SIZE INCHES	MM	ACTUAL SIZE INCHES	MM
12"x24"	305x610	11 ^{13/16"} x23 ^{47/64"}	300x603
8"x40"	203x1016	7 ^{7/8"} x39 ^{1/8"}	200x1000

*For more detailed information about the different actual sizes for non-rectified material, please contact Caesar Ceramics USA.

TERMS & CONDITIONS OF SALE

In these Terms and Conditions of Sale, Caesar Ceramics USA, Inc., is referred to as “Caesar”, and the customer or person or entity purchasing Caesar’s products (herein referred to as “Products” and “Goods”) from Caesar is referred to as the “Buyer”.

These Terms and Conditions of Sale, and Caesar’s Order confirmation constitute the complete and exclusive agreement and understanding governing the sale of Goods by Caesar to Buyer (the “Agreement”) and supersede all prior agreements, understandings or representations, whether written or oral, among the parties with respect to such matters. Provided, however, that if any term, provision or condition of Caesar’s Order confirmation should conflict or be inconsistent with any paragraph of these Terms and Conditions, then the content of Caesar’s Order confirmation shall prevail and control over such conflicting and/or inconsistent terms.

BY ACCEPTING CAESAR’S ORDER CONFIRMATION AND/OR BY ACCEPTING SHIPMENT OF PRODUCTS, BUYER ACKNOWLEDGES, ACCEPTS, AND AGREES TO THESE TERMS AND CONDITIONS.

Caesar reserves, in its sole discretion, the right to refuse any order. No order is accepted by Caesar until: (i) Caesar provides Buyer with a written Order confirmation, and (ii) Buyer duly signs the Order confirmation in acknowledgement, acceptance and agreement, and returns the signed Order Acknowledgement to Caesar.

1. **PRICES:** All prices for Goods, including, but not limited to, those specified in Caesar’s price list or schedule, website or written quotation, are subject to change without notice. Such prices shall be automatically adjusted to reflect Caesar’s prices of Products as in effect at the time of the requested shipment date, and each shipment will be invoiced at such adjusted prices. Unless otherwise expressly agreed by Caesar in writing, all prices are EX WORKS (which shall have the same meaning as in the Incoterms 2020 published by the International Chamber of Commerce), exclusive of any applicable taxes, duties, sales taxes, transportation and insurance costs or charges (collectively “Charges”), which are to be borne exclusively by Buyer.

2. **TERMS OF PAYMENT:** Unless otherwise expressly agreed by Caesar in writing in Caesar’s Order confirmation, the purchase price for all orders shall be paid in full in advance of shipment. All payments must be made in U.S. currency. In the event Buyer fails to make any payment when due, Caesar shall have the right, in addition to all other remedies available to Caesar either at law or in equity, to either terminate this Agreement immediately, without notice, or to suspend further performance under this Agreement. Buyer shall be liable for all expenses, including reasonable attorneys’ fees, relating to the collection of past due amounts. If any payment owed to Caesar is not paid when due, it shall accrue interest at the rate of the lesser of 15% per annum, or the maximum amount permitted by applicable law, from the date on which such past due amount is due until the past due amount is paid in full. Should Buyer’s financial responsibility become unsatisfactory to Caesar, cash payments or security satisfactory to Caesar may be required by Caesar for future deliveries and for the Goods theretofore delivered. If such cash payment or security is not provided, in addition to Caesar’s other rights and remedies, Caesar may discontinue deliveries.

3. **SHIPMENT AND DELIVERY:** a) Unless otherwise expressly agreed in writing by Caesar, shipments are made EX WORKS (which shall have the same meaning as in the Incoterms 2020 published by the International Chamber of Commerce). Responsibility for, and any risk of loss or damage to, the Products shall pass from Caesar to Buyer upon delivery of the Products to carrier. Any claims for shortages or damages suffered in transit are under the responsibility of Buyer and shall be submitted by Buyer directly to the carrier. Shortages or damages must be acknowledged and signed for at the time of delivery. Buyer affirmatively waives any claim for damage not acknowledged at the time of delivery. While Caesar will use all reasonable commercial efforts to maintain the delivery date(s) acknowledged or quoted by Caesar, all shipping dates are approximate and not guaranteed. Caesar reserves the right to make partial shipments. Caesar, at its option, shall not be bound to tender delivery of any Goods for which Buyer has not provided accurate shipping instructions. If the shipment of the Products is postponed or delayed by Buyer for any reason including, but not limited to, Buyer providing Caesar with inaccurate shipping instructions, then Buyer agrees to reimburse Caesar for any and all transport and/or storage costs and other additional and incidental expenses resulting therefrom.

4. **CLAIMS ON TRASPORTATION** (if applicable): In instances in which shipment is made FCA or CPT (which shall have the same meaning as in the Incoterms 2020

published by the International Chamber of Commerce) all Products must be inspected at time of arrival for visible damages and Buyer must note on the Proof of Delivery “POD” any damages prior to the delivery driver departing. Failure to note damage on the POD shall result in a waiver of any claim related to damaged Goods. If Buyer discovers concealed damages or shortages after the delivery driver has left Buyer’s premises and those damages or shortages have not been clearly specified on the POD, Buyer is required to notify Caesar’s Customer Service care department within three (3) days of the delivery in writing by e-mail to customercare@caesarceramicsusa.com, including a thorough explanation as to why the damage could not have been seen at the time of delivery.

Buyer’s claim must include all of the following information :-
- Company name
- Address where the shipment was delivered
- Delivery date
- Name of the carrier
- Order #
- Delivery #
- Description of the damage
- Quantification of the damage (how many boxes, tiles, etc.)
- Pictures of the damaged material

Upon receipt of the claim, Caesar will initiate a claim with the carrier. Caesar shall not be responsible for any reimbursement or replacement decision made by the carrier under any circumstance. Caesar cannot assure that the claim will be approved by the carrier. Damaged material subject to any claim should not be returned to Caesar without Caesar’s written prior approval and it should not be disposed of or further altered in anyway. Any allegedly damaged Goods should be clearly marked as nonconforming and stored safely until the claim is fully resolved. In the event the claim is denied by the carrier, Caesar reserves the right to also deny the claim and request payment of the corresponding invoice without deductions. Caesar is under no obligation to replace Goods that were damaged as a result of the carrier.

5. **LIMITED WARRANTY:** a) Subject to the limitations set forth in Section 6 below, Caesar warrants that Products sold by Caesar as “first choice goods” are manufactured in accordance with Caesar’s published technical standards. This limited warranty is valid only: (i) for a period of one hundred and eighty (180) days from the date of shipment of the Goods by Caesar, or (ii) for the period from the date of shipment of the Goods by Caesar until installation or attempted installation of the Goods, whichever is less. This limited warranty applies only to “first choice goods” sold by Caesar. ALL GOODS SOLD BY CAESAR OTHER THAN “FIRST CHOICE PRODUCTS” ARE SOLD AS IS. THIS IS THE SOLE AND EXCLUSIVE WARRANTY GIVEN BY CAESAR WITH RESPECT TO THE GOODS AND IS IN LIEU OF AND EXCLUDES ALL OTHER WARRANTIES, EXPRESSED OR IMPLIED, ARISING BY OPERATION OF LAW OR OTHERWISE, INCLUDING WITHOUT LIMITATION, MERCHANTABILITY AND FITNESS FOR A PARTICULAR PURPOSE WHETHER OR NOT THE PURPOSE OR USE HAS BEEN DISCLOSED TO CAESAR, AND WHETHER OR NOT CAESAR’S PRODUCTS ARE SPECIFICALLY DESIGNED AND/OR MANUFACTURED BY CAESAR FOR BUYER’S (OR ANY SUBSEQUENT TRANSFERREE’S, AS DEFINED BELOW) USE OR PURPOSE.

OTHER THAN REPRESENTATIONS OR WARRANTIES MADE BY CAESAR IN ITS LITERATURE AND/OR PACKAGING, NO REPRESENTATION OR WARRANTY OF ANY KIND REGARDING THE PRODUCTS MADE BY ANY PERSON OR ENTITY INCLUDING, BUT NOT LIMITED TO, INDEPENDENT DISTRIBUTORS AND SALES REPRESENTATIVES, SHALL BE BINDING UPON CAESAR.

IF YOU ARE A CONSUMER, AND SHOULD ANY APPLICABLE LAW PROHIBIT THE DISCLAIMER OF IMPLIED WARRANTIES SET FORTH ABOVE, THEN ANY IMPLIED WARRANTIES FOUND TO EXIST WILL BE STRICTLY LIMITED TO THE DURATION OF THE LIMITED WARRANTY SET FORTH ABOVE.

Notwithstanding the foregoing, this limited warranty does not extend to any losses or damages due to misuse, accident, abuse, neglect, normal wear and tear, negligence (other than Caesar’s), unauthorized modification or alteration, use beyond rate capacity, or improper installation, maintenance or application. To the extent that Buyer and/or its agents have supplied specifications, information, representation of operating conditions, or other data to Caesar or Manufacturer in the selection or design of the Goods and the preparation of Caesar’s quotation, and in the event that actual operating conditions or other conditions differ from those represented by Buyer, any warranties or other provisions contained herein which are affected by such conditions shall be null and void.

TILE BY ITS NATURE AND DUE TO THE VARIABILITY OF THE NATURAL MATERIAL AND PRODUCTION PROCESS ITSELF IS A MATERIAL SUBJECT TO VARIATION IN COLOR AND/OR VEINING AS WELL AS TECHNICAL SPECIFICATIONS, INCLUDING BUT NOT LIMITED TO DCOF (DYNAMIC COEFFICIENT OF FRICTION). EXPRESS TECHNICAL SPECIFICATIONS ARE NOT GUARANTEES OF MINIMUM OR MAXIMUM THRESHOLDS OF PERFORMANCE.

CAESAR DOES NOT WARRANT THAT OUR PORCELAIN TILES WILL NOT SCRATCH, CHIP OR SHOW SIGNS OF WEAR.

Buyer must notify Caesar of any defects in the Products in writing, via certified mail to Caesar Ceramics USA, at 500, Wilson Pike Circle, Ste 127, Brentwood – TN, 37027 - 3261, within thirty (30) days of Buyer’s receipt of the Goods. Failure to provide such notice within 30 days of receipt shall act as a complete bar to any claims against Caesar for any defect. Upon receiving Buyer’s notice of defect, Caesar shall, at its option, repair, correct or replace the Goods EX WORKS (which shall have the same meaning as in the Incoterms 2020 published by the International Chamber of Commerce), or refund the purchase price for that portion of the Products found by Caesar to be defective. Failure by Buyer to give such written notice within the applicable time period shall be deemed an absolute and unconditional waiver of Buyer’s claim for such defects. Goods repaired or replaced during the warranty period shall be covered by the foregoing warranty for the remainder of the original warranty period or ninety (90) days from the date of shipment, whichever is longer. Notwithstanding the provisions contained in the preceding sentences of this paragraph, Buyer shall be deemed to have accepted the Products and absolutely and unconditionally waived its rights to claim for any defects: (i) upon installation or attempted installation of the Products, or (ii) if the Products are otherwise used or altered in any way. It is Buyer’s obligation to fully inspect the Goods prior to installation or attempted installation.

Buyer assumes all other responsibility for any loss, damage, or injury to persons or property arising out of, connected with, or resulting from the use of Goods, either alone or in combination with other products/ components.

This Section 5 also applies in the event that any entity or person (other than Buyer) buys, acquires or uses the Goods, including, but not limited to, any entity or person who obtains the Products from Buyer (any of them a “Subsequent Transferee”). Buyer hereby covenants and agrees to provide such Subsequent Transferee with written notice of the provisions set forth in Sections 5 and 6 of these Terms and Conditions of Sale, by providing each such Subsequent Transferee with a copy of these Terms and Conditions of Sale, or an online link thereto, at the time of sale from the Buyer to the Subsequent Transferee. Additionally, should a Subsequent Transferee again transfer or sell the Goods to another end user, the Subsequent Transferee shall be under the same obligation to provide notice of these Terms and Conditions of sale to the end user. Buyer, furthermore, covenants and agrees that it shall not make any representation or warranty whatsoever regarding the Products to any third party (either on behalf of Caesar or on its own account), other than the limited warranty of Caesar set forth in this Section 5. BUYER HEREBY COVENANTS AND AGREES THAT, SHOULD IT FAIL TO COMPLY WITH THE PROVISIONS OF THIS PARAGRAPH, BUYER SHALL DEFEND, INDEMNIFY, AND HOLD LANDMARK, ITS OFFICERS, EMPLOYEES, AND AGENTS HARMLESS FROM AND AGAINST ANY AND ALL LIABILITY, LOSS, EXPENSE (INCLUDING REASONABLE ATTORNEYS’ FEES), OR CLAIMS FOR INJURY OR DAMAGES (INCLUDING, BUT NOT LIMITED TO GENERAL, CONSEQUENTIAL, INCIDENTAL AND PUNITIVE DAMAGES) ARISING OUT OF OR IN CONNECTION WITH BUYER’S OR BUYER’S EMPLOYEES’, AGENTS’, REPRESENTATIVES’ AND/OR INDEPENDENT CONTRACTORS’ BREACH OF THESE TERMS AND CONDITIONS OF SALE. For clarity, this Section shall control and supersede any state law providing for any indemnification to Buyer by Landmark for any claims raised by a Subsequent Transferee where Buyer has failed to comply with this Section.1

6. **LIMITATION OF REMEDY AND LIABILITY:** THE SOLE AND EXCLUSIVE REMEDY FOR BREACH OF ANY WARRANTY HEREUNDER SHALL BE LIMITED TO REPAIR, CORRECTION OR REPLACEMENT, OR REFUND OF THE PURCHASE PRICE IN ACCORDANCE WITH SECTION 5 ABOVE. BUYER, ANY SUBSEQUENT TRANSFERREE, AND ANY END USER OF THE GOODS AGREE THAT CAESAR SHALL NOT BE LIABLE FOR DAMAGES CAUSED BY DELAY IN PERFORMANCE AND, IN NO EVENT, REGARDLESS OF THE FORM OF THE CLAIM OR CAUSE OF ACTION (WHETHER BASED IN CONTRACT,

INFRINGEMENT, NEGLIGENCE, STRICT LIABILITY, INDEMNIFICATION, OTHER TORT, OR OTHERWISE), SHALL CAESAR’S LIABILITY TO BUYER AND/OR ANY SUBSEQUENT TRANSFERREES EXCEED THE PRICE PAID BY BUYER FOR THE SPECIFIC GOODS PROVIDED BY CAESAR GIVING RISE TO THE CLAIM OR CAUSE OF ACTION. THIS INCLUDES, BUT IS NOT LIMITED TO, ANY CLAIM BY BUYER, A SUBSEQUENT TRANSFERREE, OR AN END USER OF THE GOODS FOR INDEMNIFICATION OR ATTORNEYS’ FEES IN EXCESS OF THE PURCHASE PRICE BY BUYER, AND SHALL SUPERSEDE ANY STATE LAW TO THE CONTRARY. BUYER AND ANY SUBSEQUENT TRANSFERREE AGREES THAT IN NO EVENT SHALL CAESAR’S OR MANUFACTURER’S LIABILITY TO BUYER AND/OR ANY SUBSEQUENT TRANSFERREES EXTEND TO INCLUDE INCIDENTAL, CONSEQUENTIAL OR PUNITIVE DAMAGES. The term “consequential damages” shall include, but not be limited to, loss of anticipated profits, loss of business opportunity, business interruption, loss of use or revenue, cost of capital or loss or damage to property or equipment.

7. **EXCUSE OF PERFORMANCE:** Neither Caesar nor Manufacturer shall be liable for delays in performance or for non-performance due to: acts of God; acts of Buyer; war; fire; flood; weather; sabotage; strikes or labor disputes; civil disturbances or riots; governmental requests, restrictions, allocations, laws, regulations, orders or actions; unavailability of or delays in transportation; pandemic or epidemic; default of suppliers; material fluctuations in the exchange rate between the U.S. Dollar and Euro; or unforeseen circumstances or any events or causes beyond Caesar’s or Manufacturer’s reasonable control. Deliveries or other performance may be suspended for an appropriate period of time or canceled by Caesar upon notice to Buyer in the event of any of the foregoing, but the balance of the Agreement shall otherwise remain unaffected as a result of the foregoing.

If Caesar determines that its ability to supply the total demand for the Goods, or to obtain material used directly or indirectly in the manufacture of the Goods, is hindered, limited or made impracticable due to causes set forth in the preceding paragraph, Caesar may allocate its available supply of the Goods or such material (without obligation to acquire other supplies of any such Goods or material) among its purchasers on such basis as Caesar determines to be equitable without liability for any failure of performance which may result therefrom.

8. **CANCELLATION:** Buyer may cancel orders only upon reasonable advance written notice and upon payment to Caesar of Caesar’s cancellation charges which include, among other things, the costs and expenses incurred, and to cover commitments made by Caesar or Manufacturer and a reasonable profit thereon, both for Standard Products (those appearing in Caesar’s Catalog) and Custom or Made on Order Products (which means Products manufactured upon request of the Buyer, not included in the current Caesar’s Pricelist, or Products declared as “made on Order” according to the current Caesar’s Pricelist). Caesar’s determination of such cancellation charges shall be conclusive. PROVIDED, HOWEVER, THAT ANY CANCELLATION MUST BE MADE BEFORE THE GOODS HAVE BEEN SHIPPED.

9. **CHANGES OR ADDITIONS TO ORDER:** Buyer may request changes or additions to the Goods consistent with Caesar’s specifications and criteria. Caesar is not obligated, however, to accept any changes or additions. In the event such changes or additions are accepted by Caesar, Caesar may revise the price and dates of delivery, among other things, and the right to make technical and manufacturing changes to the Product(s), none of which will substantially alter the aesthetic of the Product(s), without prior notice to Buyer, except with respect to Product(s) being made-to-order for Buyer.

10. **RETURNED GOODS:** Except as otherwise provided in Section 5 above with respect to warranty defects, any and all material which Buyer desires to return and which Caesar agrees to take back will be accepted only with prior written authorization and must be in full compliance of this return policy. Caesar is under no obligation to accept a return, and returns will be accepted in its sole discretion. No returns will be accepted for discontinued material and for products other than first choice products. Returns will not be accepted unless Caesar has first issued a Return Authorization Number. Only Caesar’s Customer Service Department can authorize a return, and all return authorizations must be in writing. No sales representative may accept the return of any products without such written authorization. Products may be returned to Caesar only after inspection by Caesar and after receipt by the Buyer of shipping instructions. Returns will be charged a minimum of 25% restocking fee (unless Caesar erred in filling the order) and will be limited to full and unopened cartons that have not been

damaged or mutilated in any way. Shipping, handling, insurance, taxes, risk of loss and tariff charges for return products shall be borne by the Buyer.

11. **INDEMNIFICATION:** Buyer hereby covenants and agrees to defend, indemnify and hold harmless Caesar, Manufacturer, their officers, directors, employees, agents, advisers, representatives and affiliates (collectively, the “Indemnitees”) from and against, and pay or reimburse the Indemnitees for any and all claims, liabilities, obligations, losses, fines, costs, royalties, proceedings, deficiencies or damages (whether absolute, accrued, conditional or otherwise and whether or not resulting from third party claims), including out-of-pocket expenses and reasonable attorneys’ and accountants’ fees incurred in the investigation or defense of any of the same or in asserting any of their respective rights hereunder (collectively, “Losses”), resulting from or arising out of: (i) Buyer’s breach of any provision or covenant set forth in this Agreement, and/or (ii) Buyer’s making of any representation to any third party regarding the Goods other than the limited warranty set forth in Section 4 above.

12. **ASSIGNMENT:** Buyer shall not assign its rights or delegate its duties hereunder or any interest herein without the prior written consent of Caesar, and any such assignment, without such consent, shall be void.

13. **GENERAL PROVISIONS:** No change, modification, rescission, discharge, abandonment, or waiver of these Terms and Conditions of Sale shall be binding upon Caesar or Manufacturer unless made in writing and signed on its behalf by a duly authorized representative of Caesar or Manufacturer. No conditions, usage of trade, course of dealing or performance, understanding or agreement purporting to modify, vary, explain, or supplement these Terms and Conditions of Sale shall be binding unless hereafter made in writing and signed by the party to be bound, and no modification or additional terms shall be applicable to this Agreement by Caesar’s receipt, acknowledgment, or acceptance of purchase orders, shipping instruction forms, or other documentation containing terms at variance with or in addition to those set forth herein. No waiver by either party with respect to any breach or default or of any right or remedy, and no course of dealing, shall be deemed to constitute a continuing waiver of any other breach or default or of any other right or remedy, unless such waiver be expressed in writing and signed by the party to be bound. All typographical or clerical errors made by Caesar in any quotation, acknowledgment or publication are subject to correction.

14. **SEVERABILITY:** If any provision of this Agreement shall be held invalid or unenforceable by competent authority, such provision shall be construed so as to be limited or reduced to be enforceable to the maximum extent compatible with the law as it shall then appear. The total invalidity or unenforceability of any particular provision of this Agreement shall not affect the other provisions hereof and this Agreement shall be construed in all respects as if such invalid or unenforceable provision were omitted.

15. **GOVERNING LAW AND JURISDICTION:** This Agreement shall be governed by and construed in accordance with the laws of the State of Tennessee without reference to its conflicts of laws principles. Buyer, Caesar and Manufacturer, and any Subsequent Transferee agree to submit all disputes arising out of or in connection with this Agreement to the exclusive jurisdiction of the State and Federal courts of the State of Tennessee, located in Davidson County. EACH PARTY TO THIS AGREEMENT ACKNOWLEDGES AND AGREES THAT ANY CONTROVERSY WHICH MAY ARISE UNDER THIS AGREEMENT IS LIKELY TO INVOLVE COMPLICATED AND DIFFICULT ISSUES, AND THEREFORE, EACH SUCH PARTY HEREBY IRREVOCABLY AND UNCONDITIONALLY WAIVES ANY RIGHT SUCH PARTY MAY HAVE TO A TRIAL BY JURY IN RESPECT OF ANY LITIGATION DIRECTLY OR INDIRECTLY ARISING OUT OF OR RELATING TO THIS AGREEMENT, OR THE BREACH, TERMINATION OR VALIDITY OF THIS AGREEMENT, OR THE TRANSACTIONS CONTEMPLATED BY THIS AGREEMENT. EACH SUCH PARTY CERTIFIES THAT THEY HAVE NOT RELIED UPON ANY REPRESENTATION OR INDUCEMENT OF THE OTHER PARTY IN AGREEING TO THIS PROVISION AND THAT THEY FREELY, KNOWINGLY AND VOLUNTARILY WAIVE THEIR RIGHT TO A JURY TRIAL. The Convention for the International Sale of Goods shall not apply to this Agreement.

16. **U.S. EXPORT CONTROL REGULATIONS:** All Goods sold to Buyer are subject to the export control laws of the United States and Buyer agrees not to re-sell or divert any Goods contrary to such laws.

17. **NO THIRD PARTY RIGHTS:** These Terms and Conditions of Sale create no third party rights between Caesar and any person other than Buyer, including

but not limited to any Subsequent Transferee. It is understood and agreed that the parties do not intend that any third party be a beneficiary of these Terms and Conditions of Sale.

18. **RECOMMENDED USE OF PORCELAIN TILES & PAVERS:** Failure to comply with any of the below recommended uses will result in the Warranty provided herein becoming null and void.

RECOMMENDED USE FOR MATT FINISH PORCELAIN TILES (ALL COLLECTIONS)

These products are recommended for indoor floors, walls, countertops, and outdoor walls in commercial and residential application. The use of these products is not recommended for horizontal exterior surfaces that require anti-slip features. Caesar recommends an offset no greater than 30%, if a staggered pattern is required for tiles of 20” inches or longer.

RECOMMENDED USE FOR GRIP FINISH PORCELAIN TILES (ALL COLLECTIONS)

These products are recommended for indoor and outdoor floors and walls, in commercial and residential application, especially where antislip features are required. Caesar recommends an offset no greater than 30%, if a staggered pattern is required for tiles of 20” inches or longer.

RECOMMENDED USE FOR CHEVRON PORCELAIN TILES

These products are recommended for indoor floors, walls and outdoor walls in commercial and residential application. The use of these products is not recommended for horizontal exterior surfaces that require anti-slip features. Minimum grout joint recommended for Chevron in herringbones pattern installation is 4mm. No claim will be accepted for installations that fail to comply with such recommendation.

RECOMMENDED USE FOR 20 MM THICK PORCELAIN PAVERS (ALL COLLECTIONS)

These products are recommended for indoor floors, walls, countertops, and outdoor floor and walls in commercial and residential application. Caesar recommends an offset no greater than 30%, if a staggered pattern is required for tiles of 20” inches or longer.

COVE BASE AND BULLNOSE SHADE MATCHING WITH FIELD TILES

Regarding the use of Cove base (hereinafter referred to as “CB”) and Bullnose (hereinafter referred to as “BN”), it is extremely important to understand the following:

1) CB and BN are special pieces intended for the wall basal use only and are meant to protect the wall from water, chemicals and dirt during the cleaning activities.
2) The main difference between BN and CB is that the second one is able to transition from the floor to the wall with a rounded connection edge that allows a better cleaning action in correspondence of the contact point between wall and floor. They both have a rounded miter cut on the upper side and not a straight cut. The rounded corner is meant to be the last ceramic bit before the plain wall (not covered by tiles) begins, and it is rounded for both esthetic reasons and easier cleaning.

3) Given the use for which they have been studied BN and CB are usually never toned in association with field tiles for two main reason:

- BN and CB are installed vertically, unlike the floor that is horizontal, and hence due to the different refraction of the light their tones will appear different anyways. Consequently, it has no relevance if the tone of the tile used on the floor and the tone of the BN and CB can be combined or not. Once installed, they will look as two different tones.

- The CB is made with different equipment and raw materials from the field tiles so that the shades are even more unlikely to match. The BN may have an easier combination as it is cut down directly from the field tile, but being used vertically the light refraction will still make them appear different.

4) Both the CB and BN are not designed to joint together ceramic covered floors and walls, and that is why the upper side is rounded and not straight. Landmark Ceramics recommends NOT to use the CB nor BN, wherever a ceramic covered wall is needed above them.

5) For the above said reasons Caesar Ceramics cannot be held responsible for problems related to the tone mismatching between the aforementioned BC and CB and the relative field tiles, for which an improper use becomes evident.



WARNING

Outdoor pavings installed unglued above the ground level are subject to the action of the wind, with the risk, in some cases, of becoming airborne.

The manufacturer recommends to require the assistance of a qualified professional in order to check the suitability of the installation system above the ground adopted, in accordance with the local laws and regulations and the conditions of use.

Failure to do so could result in serious injury or property damage.

A ceramic slab installed on a raised pedestal system may fracture on impact if a heavy object is dropped onto it from a height, with a risk of injury to anyone standing or walking on such slab. Failure to adhere to the manufacturer's instructions for installation of slabs on raised pedestal systems may result in serious injury.

For further information and recommendations concerning the installation systems please refer to www.caesarceramicsusa.com website.



<https://www.caesar.it/us/caesarusa/>

Color reproductions may vary from actual products.

Caesar reserves the right to modify the products illustrated in this catalogue for reasons of production or to improve quality. Samples are purely indicative. Packaging and weights may vary for production reasons. Contact our sales department when ordering.

Caesar warrants that our products meet or exceed the requirements of ANSI, specification ANSI A137.1: 2012, as shown in our Tile Performance Data sheets.

The Caesar complete terms and conditions of sale (including limited warranty) are specified in the price list. Should you need further information, please contact our sales department.



WARNING

Outdoor pavings installed unglued above the ground level are subject to the action of the wind, with the risk, in some cases, of becoming airborne.

The manufacturer recommends to require the assistance of a qualified professional in order to check the suitability of the installation system above the ground adopted, in accordance with the local laws and regulations and the conditions of use.

Failure to do so could result in serious injury or property damage.

A ceramic slab installed on a raised pedestal system may fracture on impact if a heavy object is dropped onto it from a height, with a risk of injury to anyone standing or walking on such slab. Failure to adhere to the manufacturer's instructions for installation of slabs on raised pedestal systems may result in serious injury.

For further information and recommendations concerning the installation systems please refer to www.caesarceramicsusa.com website.

ATENCION

Las pavimentaciones exteriores colocadas en seco en altitud están sujetas a la acción del viento, con el consiguiente riesgo de levantamiento de las baldosas.

El fabricante recomienda hacer verificar la idoneidad del sistema de colocación en altitud a un técnico habilitado en base a la normativa local vigente y a las condiciones de uso, con el fin de evitar el riesgo de daños a personas y bienes.

Una baldosa cerámica colocada sobre un sistema sobreelevado puede romperse al caer sobre ella un objeto pesado desde cierta altura, con el consiguiente riesgo de lesiones graves para quienes estén pasando o se encuentren de pie sobre ella. El incumplimiento de las instrucciones del fabricante para la colocación sobre sistemas sobreelevados puede ocasionar lesiones graves.

Para más información y recomendaciones de colocación visitar nuestro sitio www.caesarceramicsusa.com.

AVERTISSEMENT

Les dallages extérieurs posés sans collage sont soumis à l'action du vent, avec le risque de soulèvement des plaques, notamment ceux posés aux étages d'un bâtiment. Le fabricant recommande de faire vérifier par un technicien qualifié la bonne adaptation du système de pose en étages avec la réglementation en vigueur et les conditions d'utilisation locales, afin d'éviter le risque de dommages aux personnes et aux biens.

Une dalle céramique posée sur un système surélevé peut se casser à la suite d'un impact d'un objet lourd qui y chuterait d'une certaine hauteur, avec le risque de sérieux dommages pour quiconque stationnerait ou transiterait sur ce carreau. Le non respect des instructions fournies par le fabricant relatives à la pose sur des systèmes surélevés peut provoquer de sérieux dommages aux personnes.

Pour toutes informations complémentaires et recommandations de pose, veuillez vous référer à notre site www.caesarceramicsusa.com.



caesarceramicsusa.com

Color reproductions may vary from actual products.

Caesar reserves the right to modify the products illustrated in this catalogue for reasons of production or to improve quality. Samples are purely indicative. Packaging and weights may vary for production reasons. Contact our sales department when ordering.

Caesar warrants that our products meet or exceed the requirements of ANSI, specification ANSI A137.1, as shown in our Tile Performance Data sheets.

The Caesar complete terms and conditions of sale (including limited warranty) are specified in the price list. Should you need further information, please contact our sales department.

WHERE
QUALITY
MEETS
DESIGN

◆ CAESAR ◆
CERAMICS USA

CAESAR CERAMICS USA INC.
500 Wilson Pike Cir, Ste 127
Brentwood TN 37027-3261



caesarceramicsusa.com